

HORIZON EUROPE PROGRAMME
TOPIC HORIZON-CL5-2022-D5-01-08
Clean and competitive solutions for all transport modes
GA No. 101084046

Zero Emission flexible vehicle platform with modular powertrains serving the long-haul Freight Eco System



ZEFES - Deliverable report

D3.5 Mapping the HRS for HD FC trucks



**Funded by
the European Union**

Deliverable No.	ZEFES D3.5	
Related WP	WP3	
Deliverable Title	D3.5 Mapping the HRS for HD FC trucks	
Deliverable Date	2025-11-30	
Deliverable Type	REPORT	
Dissemination level	Public (PU)	
Author(s)	Stefanie Van Damme (ALI) Khalis Mohammad Aryadi Sinaga (ALI) Angjelo Andoni (ALI)	
Checked by	Fernando Lopez (HIT)	2025-11-28
Reviewed by (if applicable)	Silvia Barbaro; Ted Zotos (IRU) Ben Kraaijenhagen (VUB)	2025-11-13 2025-11-14
Approved by	Omar Hegazy (VUB) – Project coordinator	2025-11-28
Status	Final	2025-11-28

Project summary

Under the European Green Deal, the EU aims to become the first CO₂-neutral continent by 2050, with a milestone of 55% emissions reduction by 2030. For road transport, Regulation (EU) 2019/1242 sets a target of 45% lower CO₂ emissions from heavy-duty vehicles (HDVs) by 2030, progressing from 15% in 2025 to 90% by 2040, based on 2019 levels. Achieving these goals requires widespread adoption of zero-emission vehicles (ZEVs), such as Battery Electric Vehicles (BEVs) and Fuel Cell Electric Vehicles (FCEVs). However, current ZEVs face limitations in range and payload, making them less viable as direct replacements for internal combustion engine (ICE) vehicles. The ZEFES project brings together OEMs, suppliers, logistics providers, and researchers to advance competitive long-haul ZEVs through efficiency improvements, scalable production, and real-world demonstrations. This deliverable investigates the availability of HRS infrastructure to support the ZEFES demonstration use cases of HD-FCEV. The work assessed the accessibility and comprehensiveness of information from existing HRS mapping to ensure efficient integration of refuelling events to long-haul logistics mission.

Publishable summary

The task of this deliverable was to map the availability of Hydrogen Refuelling Stations (HRS) infrastructure to support the demonstration of HD-FCEV. There will be 6-demo use-cases (UCs) in various routes, including Spain, Italy (2 UCs), Austria, Turkey and Sweden. However, during the mapping exercise, it became clear that a broader mapping of the infrastructure ecosystem is needed, as the current European HRS infrastructure for HD-FCEV is not sufficient to provide hydrogen along long-haul cross-border corridors. The mapping exercise was conducted at European level, and not only for the countries the demonstrations were planned.

In this deliverable, the technical specification of the HRS for HD-FCEV and related standards are discussed in Chapter 2, with the emphasis on gaseous hydrogen refuelling. In Chapter 3, the available online maps for HRS are listed and suitable HRS for the ZEFES UCs are selected in Chapter 4. The challenges and barriers on HRS infrastructure deployment are elaborated in Chapter 5, and potential solutions are discussed in Chapter 6.

Throughout the ZEFES project, it became clear that finding HRS suitable for HD-FCEV is not a straightforward process. In Europe, HRS for passenger cars with an operating pressure of 700 bar are available, in certain regions more than other. But most of those stations cannot refuel the required hydrogen mass (>50 kg) to fulfil the ZEFES use cases in 700 bars. The HRS will require a larger high-pressure hydrogen buffer on site to dispense the +50kg of hydrogen at once. Also, differences in refuelling protocol and speed, nozzle connection, working pressure and cooling capacity can be expected between HRS designed for passenger cars and HD-FCEV. The take-away message of Chapter 2 is, that **not all 700 bar HRS can serve HD-FCEV**. A preliminary assessment is necessary to verify the compatibility between the HRS and HD-FCEV, including fuelling capacity. This ensures that the station can meet the operational expectations of truck operators.

The ZEFES project used existing online, HRS availability maps, with the focus on Sweden, Austria, Spain, Italy and Turkey, to find HRS. Suitable, operational truck HRS available along the ZEFES use-case routes, were found for Austria and Sweden. In other European countries, gaps (white spots) in HRS availability along the ZEFES UCs were found. Therefore, the project partners focused on identifying planned infrastructure that could fulfil the need. Several, HRS providers and operators were contacted, especially if they have received national or AFIR funding. Unfortunately, these meetings led to the realisations that some routes will need to be readjusted, as delays, bankruptcy, closure and cancellation of truck HRS projects forced the ZEFES partners to mitigate the initial plan (Chapter 3). The final information on the ZEFES use cases will be presented in Deliverable 7.2 Overview performed use cases, due in month 47 (November 2026). As current mitigation action, the availability of HRS in Belgium, Netherlands, Germany and Luxemburg were added to the mapping exercise.

The mapping exercise and final selection of HRS is currently still ongoing; the status is given in Chapter 4. The barriers and challenges on the deployment of HD-FCEV and FCE-HRS themselves, encountered during the mapping of the HRS infrastructure are listed in Chapter 5. The main barrier identified, is that HRS and HD-FCEV technology are still evolving, leading to an investment risk and an ecosystem with low demand for hydrogen refuelling. In addition, renewable hydrogen is not available at a competitive price compared to diesel and electricity. Also, the quality of hydrogen needs to be

monitored, to avoid issues during operation of the HRS and the HD-FCEV, but inline hydrogen quality monitoring is not a standardised procedure.

Chapter 6 elaborates the solution to these obstacles including HRS funding schemes, hydrogen ecosystems organisation, projects on green hydrogen production, and projects on HD-FCEV demonstration.

Contents

1.	Introduction.....	9
2.	Current Landscape of Hydrogen Refuelling Infrastructure	10
2.1.	Types of Hydrogen Refuelling Station.....	10
2.1.1.	Refuelling Gaseous hydrogen at 350 and 700 bar.....	10
2.1.2.	Refuelling Liquid hydrogen.....	16
2.2.	Other practical considerations.....	16
2.3.	Supply chain requirements	16
2.3.1.	Strategic approach to hydrogen refuelling.....	17
2.3.2.	Infrastructure recommendation from AFIR.....	17
2.3.3.	Survey from HD-ZEV stakeholders.....	17
3.	HRS Infrastructure Mapping.....	19
3.1.	Map of H2 Mobility – H2.LIVE.....	19
3.2.	Initiatives of Clean Hydrogen Partnership	21
3.2.1.	European Hydrogen Refuelling Station Availability System - H2-map	21
3.2.2.	European hydrogen observatory - Geomap.....	23
3.3.	European Alternative Fuels Observatory – TENtec map	25
3.4.	Regional maps and maps of HRS operators.....	27
3.5.	Discussions with HRS operators.....	29
4.	Mapped infrastructure along the TEN-T corridor	30
4.1.	Italy to Germany	30
4.2.	Sweden.....	33
4.3.	Benelux and Germany.....	34
4.4.	Spain.....	35
5.	Challenges and barriers on HRS deployment for long-haul logistics with HD-FCEV	36
5.1.	Limited technological readiness	36
5.2.	Renewable hydrogen availability and cost	36
5.3.	Fuel quality and purity	37
5.4.	Accessibility of HRS capability data.....	37
5.5.	Low station utilization.....	37
5.6.	Uncertain vehicle residual value.....	38
6.	Solutions for HRS and HD-FCEV deployment	39

6.1.	Important European and national organisations and funding schemes	39
6.1.1.	European Hydrogen bank	39
6.1.2.	Clean Hydrogen Partnership.....	39
6.1.3.	Hydrogen Europe.....	40
6.1.4.	National hydrogen associations	40
6.2.	European and national funding for HRS	41
6.3.	Projects on green hydrogen production.....	41
6.4.	European and national demonstration projects of heavy-duty vehicles.....	43
6.4.1.	JIVE and JIVE2 - Bus demonstration projects	43
6.4.2.	REVIVE project	43
6.4.3.	H2Share	44
6.4.4.	H2Haul	44
6.4.5.	H2Accelerate	45
6.4.6.	ZEFES, ESCALATE and EMPOWER	45
6.4.7.	Hyundai Hydrogen Mobility.....	46
7.	Contribution	47
7.1.	Contribution to ZEFES	47
7.2.	Contribution to exploitable results.....	47
8.	Conclusion and Recommendation	48
8.1.	Conclusion.....	48
8.2.	Recommendations	48
9.	Risks and interconnections.....	49
9.1.	Risks/problems encountered.....	49
9.2.	Interconnections with other deliverables.....	49
	References.....	50
	Acknowledgement.....	53

List of Figures

Figure 1: Schematic overview on how fuel-cell electric vehicles communicate with the HRS	11
Figure 2: Standards related to fuelling protocols, hydrogen quality and safety for gaseous HRS (Hytruck, 2024).....	13
Figure 3: Refuelling station scheme for gaseous hydrogen with a cascade refuelling (A World Of Energy, 2022).....	13
Figure 4: Different hydrogen nozzles and receptacles are available depending on the working pressure and refuelling speed (A World Of Energy, 2022).....	15
Figure 5 Driving mileage target between refuelling.....	17
Figure 6: Results of D1.5 stakeholder survey	18
Figure 7: The H2. LIVE map of H2Mobility maps.....	20
Figure 8 Variety of information on station operations	20
Figure 9 Status of non-operational HRS	21
Figure 10: Interactive Map of E-HRS-AS – H2-map	22
Figure 11 HRS operational information.....	22
Figure 12 More details on access and payment option	23
Figure 13: European hydrogen observatory infrastructure map	23
Figure 14 : Statistic figure of alternative fuel vehicles	26
Figure 15: Visualisation of the TENtec interactive map	27
Figure 16 Information on HRS operations.....	27
Figure 17 Company’s own HRS locator map	28
Figure 18 Hydrogen infrastructure by France Hydrogene	28
Figure 19: Italy to Germany corridor.....	31
Figure 20: Swedish corridor.....	33
Figure 21 HRS in Benelux - North Rhine	34
Figure 22 Potential HRS location for early development in Spain	35
Figure 23: Mobile HRS demonstration of H2Share	44

List of Tables

Table 1 Major standards and directives on HRS design and operation	12
Table 2: The different elements in the dashboard of the European Hydrogen Observatory	24
Table 3 Mapping of HRS along the original UC demonstration routes	30
Table 4 HRS Infrastructure around depot (IT – DE).....	32
Table 5 HRS Infrastructure density Italy to Germany corridor.....	32
Table 6 HRS infrastructure mapped for UC Sweden	33
Table 7 HRS in Benelux to Germany.....	34
Table 8 Risk assessment and counter measures	49

Abbreviations & Definitions

Abbreviation	Explanation
AFIR	Alternative Fuels Infrastructure Regulation
API	Application Programming Interface
ATEX	Explosive Atmospheres
CCS	Combined Charging System
CEF	Connecting Europe Facility
EAFO	European Alternative Fuels Observatory
E-HRS-AS	European Hydrogen Refuelling Station Availability System
GCW	Gross Combination Weight
HDV	Heavy-Duty Vehicle
HD-ZEV	Heavy-Duty Zero Emission Vehicle
HD-BEV	Heavy-Duty Battery Electric Vehicle
HD-FCEV	Heavy-Duty Fuel Cell Electric Vehicle
HRS	Hydrogen Refuelling Station
IR	Infra-Red
ICE	Internal Combustion Engine
ISO	International Standards Organization
MCS	Megawatt Charging System
OEM	Original Equipment Manufacturer
SAE	Society of Automotive Engineers
SMR	Steam Methane Reforming
SoC	State of Charge (%)
TEN-T	The Trans-European Transport Network
UC	Use Case

1. Introduction

This work presents an overview of the available hydrogen refuelling infrastructure in Europe for heavy-duty Fuel Cell Electric Vehicles (HD-FCEV). The deliverable aims to identify the required infrastructure to conduct the ZEFES HD-FCEV use cases, map existing hydrogen refuelling system (HRS), explore ongoing projects related to the HRS infrastructure, as well as the potential funding schemes.

This deliverable is part of the ZEFES project milestone. Previous work in ZEFES has defined HRS requirements, related to the capabilities of the HD-FCEV on [D2.1. Vehicle simulation platforms](#) and Use case demonstration plan on D7.1 Use case menu card (sensitive deliverable) and [D1.4 Supply Chain Mapping](#).

The report is arranged as follows. Chapter 2 will elaborate on the working principles of HRS for HD-FCEV. The technicalities of HRS for HDV differ from the stations designed for passenger cars. Most infrastructure currently available along the use case corridors, are designed for passenger cars. Further investigation is needed to clarify the compatibility of the existing stations to refuel HD-FCEV.

In Chapter 3, the available maps for HRS and platforms are discussed and used to find suitable HRS for the ZEFES UCs (Chapter 4). Chapter 5 presents the challenges of HRS and HD-FCEV deployment, with the available of suitable hydrogen refuelling infrastructure as one of them. In Chapter 6 relevant solutions are proposed, as further research and collaboration on national and European level.

The findings will serve as a reference to establish a road-map towards zero-emissions HDV, in particular highlighting the critical infrastructure needs to be built along TEN-T corridors, so corridors for HD-FCEV can be established.

2. Current Landscape of Hydrogen Refuelling Infrastructure

The aim of this Chapter is explaining relevant technical specifications of HRS, with the focus on gaseous hydrogen refuelling at 700bar and the differences in HRS for passenger cars and HD-FCEVs. The standards and components of gaseous HRS are explained in detail. The status on refuelling liquid hydrogen is shortly addressed.

2.1. Types of Hydrogen Refuelling Station

Currently most of the HRS in Europe refuel gaseous hydrogen at a pressure of 350 or 700 bar. Passenger cars have an operating pressure of 700 bar. In earlier fuel cell vehicle projects, such as buses (JIVE 2, 2025) and refuse trucks (H2Share, 2019), the vehicles were designed for 350 bar filling pressure. As a result, several HRS were specifically designed to accommodate 350-bar refuelling for heavy-duty vehicles.

Nevertheless, in ZEFES and other ongoing projects, we see that the operating pressure standard for trucks is changing from 350 to 700 bar, since the pressure increase will lead to more hydrogen mass on the truck and a greater driving range. The HRS design must be adjusted to be able to refuel +50kg of hydrogen at once as explained in subsection 2.1.1.3.

Increasing the driving range can also be done by fuelling liquid hydrogen, increasing the mass of hydrogen on the vehicle even more. Project demonstrating the technical feasibility of fuelling liquid hydrogen and driving a liquid hydrogen truck are ongoing. The technology is discussed shortly in Section 2.1.2.

2.1.1. Refuelling Gaseous hydrogen at 350 and 700 bar

Most of the HRS in Europe and worldwide dispense gaseous hydrogen and their design is based on a cascade refuelling protocol (NewBusFuel Project, 2017). In cascade refuelling the hydrogen is compressed to a pressure higher than the operating pressure of the vehicle. The HRS releases its hydrogen at higher pressure into the vehicle (lower pressure) during fuelling.

Since hydrogen is a gas, the amount of hydrogen that can be refuelled into the vehicle is depending on the ambient temperature and the conditions (pressure and temperature) in the vehicle and the HRS. The parameter to define the ‘fulness’ of the vehicle is the State of Charge (SoC). This term is also used for battery charging. The definition of SoC in hydrogen refuelling is:

$$SoC = \frac{\rho_{T,P \text{ achieved}}}{\rho_{15^{\circ}C, \text{working } P}}$$

The SoC is the ratio of the hydrogen density ρ at the end of the refuelling, on the hydrogen density ρ which is related to the working pressure of 350 or 700 bar and 15°C. The density to reach 100% SoC is for vehicles with an operating pressure of 350 bar 23.3 g/L, and for vehicles with an operating pressure of 700 bar 40.2 g/L.

For example, if the density of the hydrogen gas in a vehicle with a working pressure of 700 bar, is 40.2 g/L at the end of the refuelling, a SoC of 100% is attained, even if the pressure and temperature in the vehicle are higher or lower than 700 bar and 15°C.

In the next Sections the protocols and standards regarding HRSs, the components of an HRS for gaseous hydrogen and the differences between HRS for passenger cars and HD-FCEV are discussed.

2.1.1.1. Protocols and standards regarding HRS for gaseous hydrogen

The main protocols and standards regarding HRS describe the fuelling protocol, the hydrogen quality, communication between vehicle and HRS and the safety measures Table 1.

The **fuelling protocol** defines the speed of the refuelling event based on the initial temperature and pressure in the vehicle (if known), the working pressure of the vehicle (350 or 700 bar), the cooling temperature of the hydrogen (if needed) and the ambient temperature. From these parameters the fuelling speed (Average Pressure Ramp Rate – APPR expressed in MPa/min) is defined as stated by the relevant fuelling protocol.

Several fuelling protocols are available. The different versions of SAE J2601 are the most common one, with SAE J2601-1 for passenger cars and SAE J2601-5 for high-flow heavy-duty vehicles. SAE J2601-1, the refuelling protocol for cars, covers also a category D, in which more than 10 kg of hydrogen is refuelled at once. This category D makes it possible to refuel both passenger cars (less than 10 kg) and heavy-duty vehicles with the same dispenser and fuelling protocol. The fuelling speed in SAE J2601-1 is limited to 60g/s (when the hydrogen is cooled to -40°C pre-refuelling) (Hytruck, 2024).

A higher refuelling speed can be attained for heavy-duty vehicles, as described in SAE J2601-5. Nevertheless, higher refuelling speeds require specific nozzle and receptacles, which leads to no interoperability with cars, meaning this cannot be safely and efficiently refuelled using the SAE J2601-5 protocol. There is also an ISO norm on hydrogen refuelling protocols: ISO 19885-1. In the PRHYDE project, a high flow refuelling protocol for heavy-duty vehicles was prepared (PRHYDE, 2024).

As stated earlier, the refuelling speed can be based on the temperature and the pressure in the vehicle. These parameters can only be known if the HRS and the vehicle communicate with each other. In SAE J2799, **the hardware and software standards for communication** are described. Commonly, the communication is done by IR (Infra-Red) connection integrated in the nozzle and receptacle (Figure 1). IR-communication is not a must for all refuelling protocols, heavy duty vehicles can be fuelled safely at 350 bar and 700 bar without communication, or communication loss. However, communication is a must to achieve an efficient and complete refuelling.

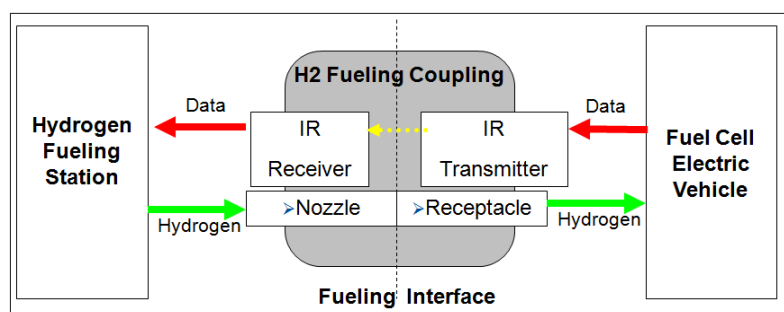

Figure 1: Schematic overview on how fuel-cell electric vehicles communicate with the HRS

The combination of fuelling protocol and communication define the hydrogen refuelling speed, the total mass of hydrogen refuelled and the SoC attained at the end of the refuelling, all important parameters that define the performance of the HRS.

Another important aspect is **the quality of hydrogen**. Hydrogen to be used in fuel-cells needs to be pure, 99.99%. Strict limits for contaminants like water, CO and sulphur compounds are defined in SAE J2719 and ISO 14687. The quality of hydrogen produced by electrolysis is already high. Water contamination is the most common and can be removed with drying. If the hydrogen is produced by Steam Methane Reforming (SMR) from methane, the risk of contaminants as CO and sulphur compounds is higher. The quality of the hydrogen is important as it impacts the operation of the HRS and the lifespan of the vehicle fuel-cell. For example, water contamination is mostly not critical for the fuel-cell, while in HRS it can form ice in the cooling step, leading to malfunction of the HRS. The quality of the hydrogen is guaranteed by the supplier, nevertheless contaminations and liability discussions occur in practice.

Regarding **safety**, the ISO 19880 series specify safety aspects for gaseous hydrogen refuelling, especially for passenger cars. General requirements, requirements for dispenser hoses, valves and other hardware are defined. The standards state that a risk analysis needs to be made for each HRS, and that additional safety measures need to be taken when necessary. Examples of safety measures are fire and leak detection, break-aways for the fuelling hoses and explosion hatches. As hydrogen is a flammable gas, the ATEX directive needs to be followed. Safety distances must be respected (especially if other fuels are at the same site), grounding of all material and minimizing the risk of sparks (no cigarettes and cell phones) is mandatory.

Hydrogen storage falls under the Seveso directive when exceeding 5 tonnes of hydrogen stored and furthermore, due to the high-pressure storage vessels, the directive on Pressure Equipment must also be followed.

Updates and new versions of the standards are to be expected. An overview of the upcoming standards can be found in Figure 2.

Table 1: Major standards and directives on HRS design and operation

Standard	Description
SAE J2601-5	High Flow Prescriptive Fuelling Protocol for Gaseous Hydrogen Powered Medium and Heavy-Duty Vehicles
ISO 19885-1	Fuelling protocols for hydrogen-fuelled vehicles. Part 1: Design and development process for fuelling protocols.
SAE J2799	Hydrogen Surface Vehicle to Station Communications Hardware and Software
SAE J2719	Hydrogen Fuel Quality for Fuel Cell Vehicles
ISO 14687	Hydrogen fuel quality – Product specification
ISO 19880	Gaseous Hydrogen – Fuelling stations
Directives	Description
ATEX	Mandates requirements for equipment used in potentially explosive atmosphere
Seveso	Applies to sites with large quantities of hazardous substances
Pressure Equipment	Mandates requirements for equipment under pressure

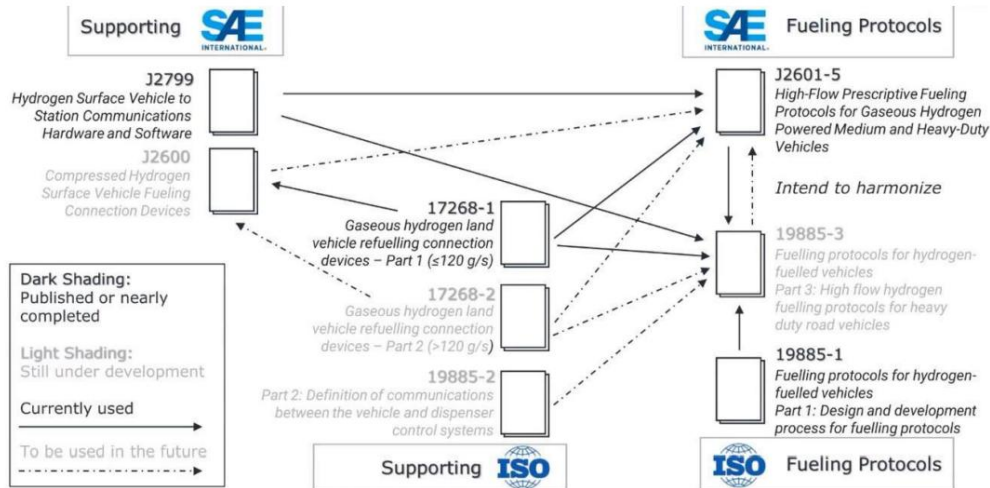

Figure 2: Standards related to fuelling protocols, hydrogen quality and safety for gaseous HRS (Hytruck, 2024)

2.1.1.2. Components of HRS for gaseous hydrogen

HRS dispensing gaseous hydrogen consist generally of the following parts (Figure 3):

- Hydrogen source
- Compressor(s)
- High pressure storage banks (cascade tanks)
- Hydrogen dispenser (with cooling and control valve)

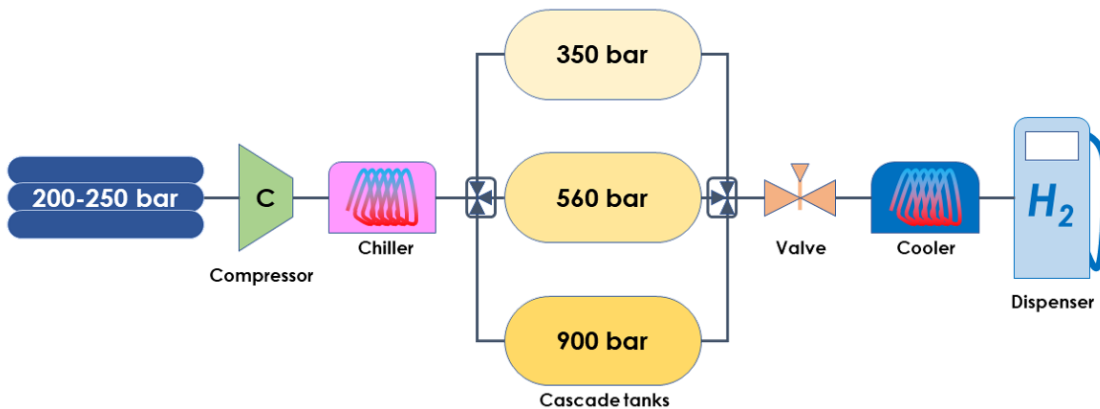

Figure 3: Refuelling station scheme for gaseous hydrogen with a cascade refuelling (A World Of Energy, 2022).

1. **Hydrogen Source: Local hydrogen production, or hydrogen delivery via tube trailer**

When local hydrogen production (electrolysis) is in place, the hydrogen will enter the HRS at a pressure of approximately 10 bar, further compression will be needed.

Tube trailers can deliver hydrogen at a station. They can stay at the HRS premise as additional hydrogen storage or empty their content in a hydrogen dump storage. Overall, using tube trailer delivery will lead to a higher starting pressure (200-500bar), but the pressure in the tube trailer declines when emptied through refuelling. Special attention to avoid contamination of the hydrogen during the delivery process should be given. Impurities, like water, COx, could affect the HRS or the fuel cell in the vehicle.

Both methods to get the hydrogen on the site HRS, needs hydrogen compression to a higher-pressure level.

2. One or two compression steps

Depending on the operating pressure of the vehicles to refuel, and how the HRS is designed, one or several compression steps are needed. Compressors can be installed in parallel to increase the reliability of a HRS. Several compressor types can be found on the market. The selection of the compressor technology and capacity is based on HRS design, the targeted reliability, and the risk of impurities.

3. High pressure storages (at different pressures for optimal cascade refuelling)

The pressurised hydrogen is stored in banks. The operating pressure of the storage banks can be set to different pressures to optimise the HRS operation and the refuelling.

During cascade refuelling the hydrogen is released to the vehicle at a lower pressure, following a certain fuelling protocol. Using hydrogen at different pressure levels, is more optimal, as it will require less energy to pressurise the hydrogen and it will lead to lower pressure losses during refuelling and less heat generated by the reversed Joule-Thomson effect (see cooling). During fuelling the pressure in the vehicle will rise and the pressure in the HRS high pressure storage banks will reduce. The refuelling will end when the State of Charge (SoC) is 100% or the pressure in the banks and the vehicle is in equilibrium.

4. Cooling

Hydrogen is a peculiar gas that heats up when isenthalpic decompressed (reversed Joule-Thomson effect). The generated heat needs to be removed by cooling since, some type of the hydrogen storage vessels has a plastic liner, and the temperature of the hydrogen needs to be lower than 85°C to not affect the plastic liner properties. The cooling of the hydrogen is defined by the working pressure of the vehicle and the followed refuelling protocol. Cooling is not a mandatory requirement for 350 bar refuelling but is mandatory for 700 bar refuelling. The common temperature to cool down to for 700 bar refuelling is -40°C. At -40°C a high refuelling speed (normal flow 60g/s) can be achieved, if this cold temperature is not achieved within 30s of the refuelling start, the refuelling protocol will fall back to a slower fuelling speed. In conclusion, the cooling step determines the refuelling speed and the final SoC.

5. Dispenser, fuelling hose, nozzle and connection on the vehicle (receptacle)

The connection between vehicle and HRS should be able to withstand high pressures and cold fluids. Special attention in the design needs to be giving to the formation of ice, for example to avoid the nozzle freezing to the vehicle.

There are different nozzles and receptacles available on the market, one per working pressure and refuelling speed combination (Figure 4).

Commonly 350 bar nozzles are compatible with 700 bar receptacles, if the mass flow is the same. This means that a passenger car can be refuelled with a 350-bar nozzle, designed for normal flow (NF, 60g/s). The compatibility between the nozzle and the vehicle connection needs to be checked prior fuelling, to make sure refuelling is possible.

The nozzle and vehicle connection can also be equipped with IR-communications.

Other important parts of an HRS are the safety equipment (leak and fire detection, venting lines, explosion hatches) and the control and steering (valves).

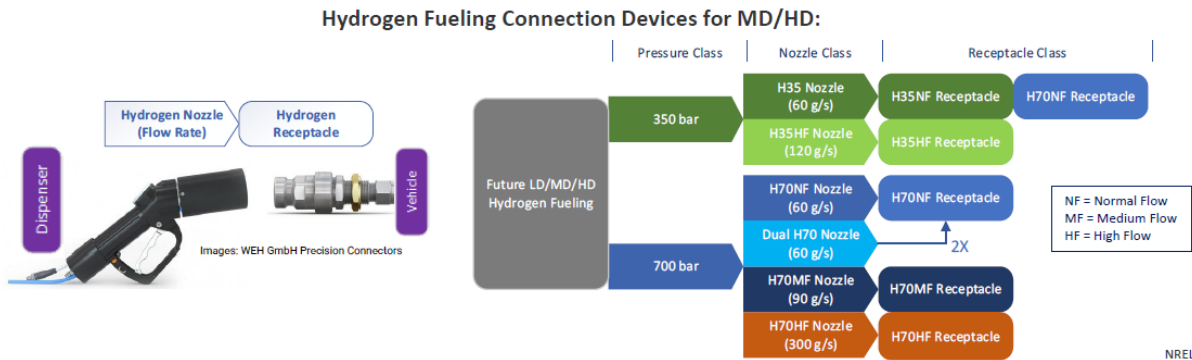

Figure 4: Different hydrogen nozzles and receptacles are available depending on the working pressure and refuelling speed (A World Of Energy, 2022)

2.1.1.3. Differences between HRS for trucks and passenger cars

All ZEFES HD-FCEV will have a working pressure of 700 bar. The main difference between an HRS for passenger cars and HD-FCEVs is the amount of hydrogen that can be refuelled at once. Passenger car HRS are designed to fuel between 5-10 kg per refuelling and this for a certain amount of back-to-back refuelling events attaining a SoC above 95%.

Refuelling a truck will need 40-100 kg of hydrogen at once. This means that the buffer size design for passenger and HD-FCEV HRS is different. Also, the compressor capacity will need to be higher in HD-FCEV stations, if a high level of service (several back-to-back refuelling events with high SoC) is targeted.

The refuelling speed for passenger cars is normal or medium flow (60 or 90g/s). Higher refuelling speeds, between 120 and 300g/s, are targeted for HD-FCEV refuelling in current and future refuelling protocols (PRHYDE, 2024). Such high refuelling speeds can only be achieved, when the HRS is designed for it. The nozzle of the station and receptacle on the vehicles need to withstand the pressure and mass flow. The cooling power needs to be adjusted, and the pressure drop in the pipelines need to be minimised. In addition, due to the larger hydrogen vessels on HD-FCEV, the parameters of the leak test at the beginning of a refuelling event will need to be reassessed.

Overall, it can be concluded that not all 700 bar HRS for passenger cars are capable to refuel HD-FCEV, hence specific HRS need to be designed, which can attain high refuelling speeds (plus 120 g/s) and high SoC for several back-to-back refuelling events.

2.1.1.4. Mobile hydrogen refuelling stations for gaseous hydrogen

Besides stationary HRS, on a fixed location, at commercial size, mobile hydrogen refuelling stations, which can be installed temporarily, are used in many demonstration projects. Several mobile refuelling stations providers are active in Europe and are leasing them to hydrogen demonstration projects. These stations can provide hydrogen at 350 or 700 bar and are perfect to supply a small fleet of vehicles. Since they are temporarily solutions, have a smaller footprint and lower mass of hydrogen stored, the permitting process can be easier. During the mapping exercise, placing a mobile hydrogen station for gaseous hydrogen was investigated as mitigation action.

2.1.2. Refuelling Liquid hydrogen

Hydrogen liquifies at temperatures below -253°C (20K). Liquid hydrogen has a much higher volumetric energy density compared to gaseous storage. Hence by using liquid hydrogen instead of gaseous hydrogen, more hydrogen could be stored at the vehicle. This is particularly interesting in the case of hydrogen transport and distribution, and to increase the HDV driving range. Nevertheless, liquifying hydrogen require energy. Current processes need 10-12 MJ/kg, which is significant. The production of hydrogen by electrolysis consumes around 55 MJ/kg.

A disadvantage of using liquid hydrogen is the boil-off, the process of liquid hydrogen vaporising due to heat influx. Due to the boil-off liquid hydrogen cannot be stored over a long time. Therefore, it needs to be used in applications with a high utilisation rate. Liquid hydrogen can be a viable option for HD-FCEV, particularly when vehicles continuously over long distances. However, it is less suited for passenger cars, which tend to remain stationary for extended periods. It raises the risk of hydrogen boil-off and the need for venting. To mitigate this, compressing the cryogenic liquid before can help reduce boil-off losses and improve system efficiency.

The refuelling process transfers liquid hydrogen from the station's insulated storage tanks to the vehicle's onboard tanks via specially designed cryogenic pumps and transfer lines. Fuelling liquid hydrogen does not require compression or cooling. An HRS for liquid hydrogen can have a simpler design and lower energy need than an HRS for gaseous hydrogen. Another advantage of liquid hydrogen refuelling is the high hydrogen quality. Liquid hydrogen does not contain any impurities.

Demonstration projects on refuelling liquid hydrogen are ongoing. One example is the Mercedes-Benz GenH2 prototype truck, tested as part of the GenH2 project (Daimler Truck AG, 2023). The refuelling took place at the Daimler truck's filling station. Cryogenic liquid hydrogen at -253°C was filled into two 40 kg tanks mounted on either side of the truck chassis. The hydrogen is supplied by Air Liquide with renewable origin from biomethane. Further research is needed to determine what will be the technologically and economically the best way to refuel and store hydrogen on heavy-duty vehicles.

2.2. Other practical considerations

Besides the technical design of the HRS, the HRS site layout is also an important aspect to be considered. HD-FCEV needs to be able to access the hydrogen dispenser in a safely manner and be able to manoeuvre without a risk for collision which is not always the case at existing HRS designed for passenger cars. The receptacle can be placed on the right or left side of the HD-FCEV. The hydrogen dispenser needs to be designed in such way that it can supply both sides.

Lastly, heavy-duty vehicles (HDV) with hydrogen combustion engines are also in development. It is expected that refuelling them will be done in the same way as HD-FCEV. Some HRS state that they do not service HDVs with a hydrogen combustion engine.

2.3. Supply chain requirements

To ensure HD-FCEVs remain competitive for long-haul logistics, both the vehicles and supporting infrastructure must be reliable. This study examines supply chain requirements from the perspectives of hydrogen supply, regulatory frameworks, and customer demand.

2.3.1. Strategic approach to hydrogen refuelling

The UC demonstration evaluates the feasibility of HD-FCEVs for long-haul logistics, targeting a 750 km range ideally achievable with one fill (see Figure 5). This distance aligns with a typical one-shift drive, allowing adaptation of existing routes currently served by Internal Combustion Engine (ICE) trucks. To meet this target, refuelling stations must be equipped to support HD-FCEV requirements, as outlined in Section 2.1.1.3, and operators must ensure sufficient hydrogen supply.



Figure 5: Driving mileage target between refuelling

2.3.2. Infrastructure recommendation from AFIR

The AFIR states that HRS should be deployed along the TEN-T road network or **within 10 km driving distance from the nearest exit of a TEN-T road**. Within urban nodes, public authorities are encouraged to install **the hydrogen refuelling stations at multimodal hubs**, as these are common destination for heavy-duty vehicles and can also serve other transport modes, such as rail and inland shipping

By 31 December 2030, Member States are required to ensure the deployment of publicly accessible HRS along the TEN-T core network, with each station offering a minimum cumulative capacity of 1 tonne per day and equipped with at least one 700-bar dispenser. **These stations should be placed no farther than 200 km apart**. This regulation highlights three key dimensions for assessing HRS infrastructure adequacy:

- **Station Density:** Ensuring appropriate spacing between stations to support reliable logistics operations.
- **Accessibility:** Locating stations near major routes and ensuring they are accessible to HD-FCEVs to avoid unnecessary detour.
- **Strategic Positioning:** Prioritizing locations near multimodal hubs to maximize utilization and support a broader range of hydrogen use cases.

Source: Regulation (EU) 2023/1804 of the European Parliament and of the Council of 13 September 2023 on the deployment of alternative fuels infrastructure, and repealing Directive 2014/94/EU (Text with EEA relevance) (European Union, 2023).

2.3.3. Survey from HD-ZEV stakeholders

A survey involving HD ZEV ecosystem has been carried out in the preceding deliverable 1.5 [Supply chain needs](#). The respondents covered various stakeholders' group of truck's manufacturer and users. The survey identified interdependencies between stakeholders as seen on Figure 6.

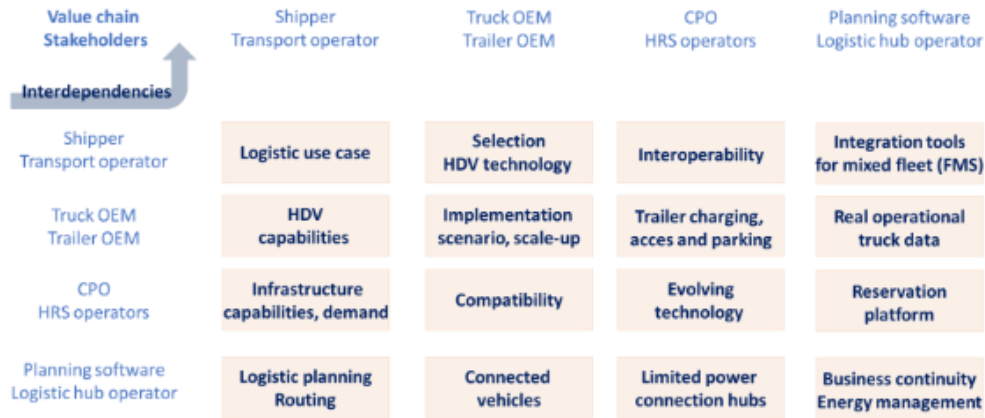

Figure 6: Results of D1.5 stakeholder survey [reference – Deliverable on Cordis]

While the survey was conducted on the context of HD ZEV, including HD BEV, several specific needs emerged related to **hydrogen infrastructure**. One of the primary concerns for truck end-users is the interoperability between HD-FCEV and refuelling infrastructure. This concern often outweighs the emissions reduction goals such as obtaining green hydrogen sources, as user prioritize the ability to refuel at any facilities. In addition, the availability of nearby HRS remains a challenge to ensure operational flexibility.

From the perspective of infrastructure providers, increasing the working pressure from 350 to 700 bar for HDV significantly impacts the HRS design. Many of the required hardware components and communication protocols are not yet fully available. This added complexity means that operators need certainty around future demand to justify investments in 700 bar HRS. While higher pressure refuelling offers clear operational benefits, such as increasing driving range and faster refuelling times, the viability of the refuelling station business model must be carefully evaluated to ensure long-term sustainability.

3. HRS Infrastructure Mapping

Several HRS have been established throughout Europe. These infrastructures are currently operated by various operators, offering service for both private and commercial vehicles. Given the specific requirements of HD-FCEV, having a visibility on available and compatible HRS along the TEN-T corridor is prominent.

In this Chapter, interactive maps, available online, are elaborated. These maps were used to find suitable HRS of the ZEFES use cases. Nevertheless, the information on the maps was not sufficient and some gaps were found along the ZEFES corridors where no HRS were/are available. Therefore, the ZEFES consortium contacted HRS operators to confirm that the HRS are suitable for HD-FCEV and requested information on planned HRS.

Four existing platforms which provide mapping of HRS, are presented in this section. The map developed by **H2 mobility** and **European Hydrogen Refuelling Station Availability System** provide a real-time status of station availability. Meanwhile, **Clean Hydrogen Partnership** and **European Alternative Fuel Observatory** provide strategic level information monitoring the progress of infrastructure development.

Lastly, HRS operators can have their own online maps, just as regional maps regarding hydrogen activities. Some examples of them are listed in section 3.4.

3.1. Map of H2 Mobility – [H2.LIVE](#)

H2 Mobility was founded in 2015, by six leading industrial companies, focusing on promoting hydrogen as an emission-free fuel for road transport. The company has been building and operating public hydrogen station network ever since, currently being one of the largest operators in Europe. They have realised over 100 HRS projects.

H2 Mobility launched a platform that gathers all information regarding HRS for cars, buses, and trucks. The website, [H2.live](#), provides a map of available HRS location as shown in Figure 7. The information on the website is regularly updated through an API, which helps drivers to locate the nearby station and avoiding detour due to station outage. Users may choose to visualize the type of station (350 or 700 bar). The map also provides information on future opening HRS, highlighted in blue circle. These insights may serve as a basis for future logistics route planning aiming to implement HD-FCEV. Any unavailable station will be marked in red circle. Operation manager and truck drivers can check availability prior the mission.

Other information regarding the station operation are also presents as seen on Figure 8.

- Status of the HRS: operational, under construction (expected opening date), under maintenance.
- The last refuelling with the refuelled mass remarks, although not always present.
- Operational time and traffic flow statistics.
- Operating pressure cars and trucks can refuel.
- Payment options and hydrogen price.
- Renewable H2 remarks.

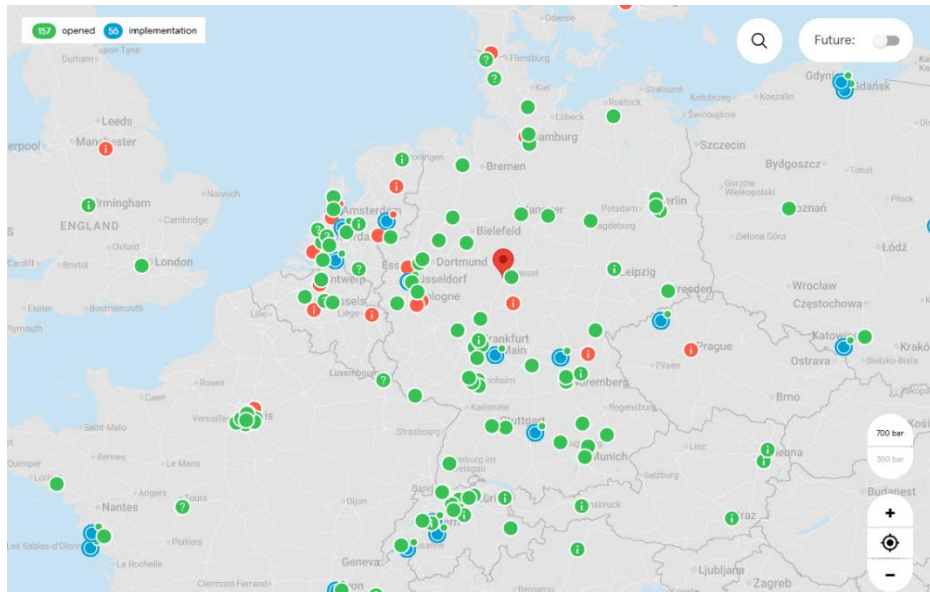
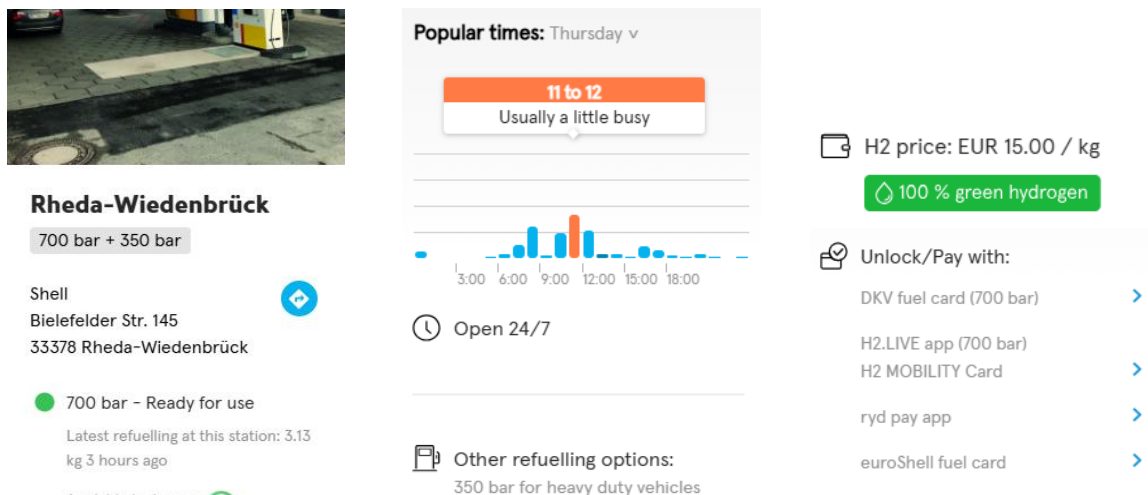

Figure 7: The H2.LIVE map of H2Mobility maps

According to their website, operators may register their publicly accessible facility to appear on the map, allowing them to gain better market exposure among hydrogen vehicles users. There are two refuelling options, 350 bar (trucks and buses) and 700 bar (cars), where each station needs to provide a minimum of 40 kilograms hydrogen capacity every day.



(a) Location, availability, last refuelling history

(b) Operational time and statistics

(c) Price, payment, and green hydrogen sources

Figure 8: Variety of information on station operations

In addition, the platform shows not only operational and active stations, but also facilities currently suspended. Figure 9 (a) shows an example of HRS currently out of service due to technical failures. While recently opened facilities may still under optimisation mode, details on which services are available is presented as seen on Figure 9 (b).

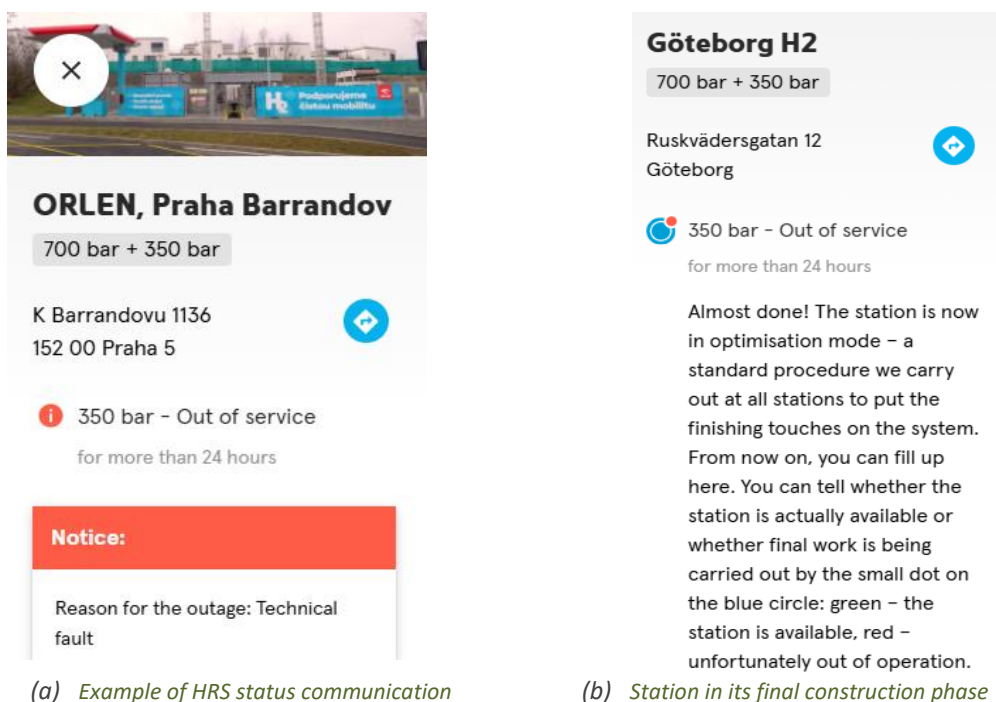

(a) Example of HRS status communication

(b) Station in its final construction phase

Figure 9 Status of non-operational HRS

3.2. Initiatives of Clean Hydrogen Partnership

The Clean Hydrogen Partnership (CHP) has launched two initiatives to support infrastructure mapping:

- i. European Hydrogen Refuelling Station Availability System
- ii. European Hydrogen Observatory

While the first serves as HRS locator, the latter provides a broader hydrogen value chain dashboard, offering data on hydrogen production facilities and end-use.

3.2.1. European Hydrogen Refuelling Station Availability System - [H2-map](#)

The European Hydrogen Refuelling Station Availability System (E-HRS-AS) is initiated to gather a reliable database regarding the status (real time monitoring) of hydrogen refuelling infrastructure from operators all over Europe. Each HRS owner may register their HRS to be part of the E-HRS-AS. The map is shown on Figure 10. The status of HRS is represented by an icon, with various states explained in the map legend. Their website claimed that the refuelling station status is updated every minute to ensure actual availability for the users.

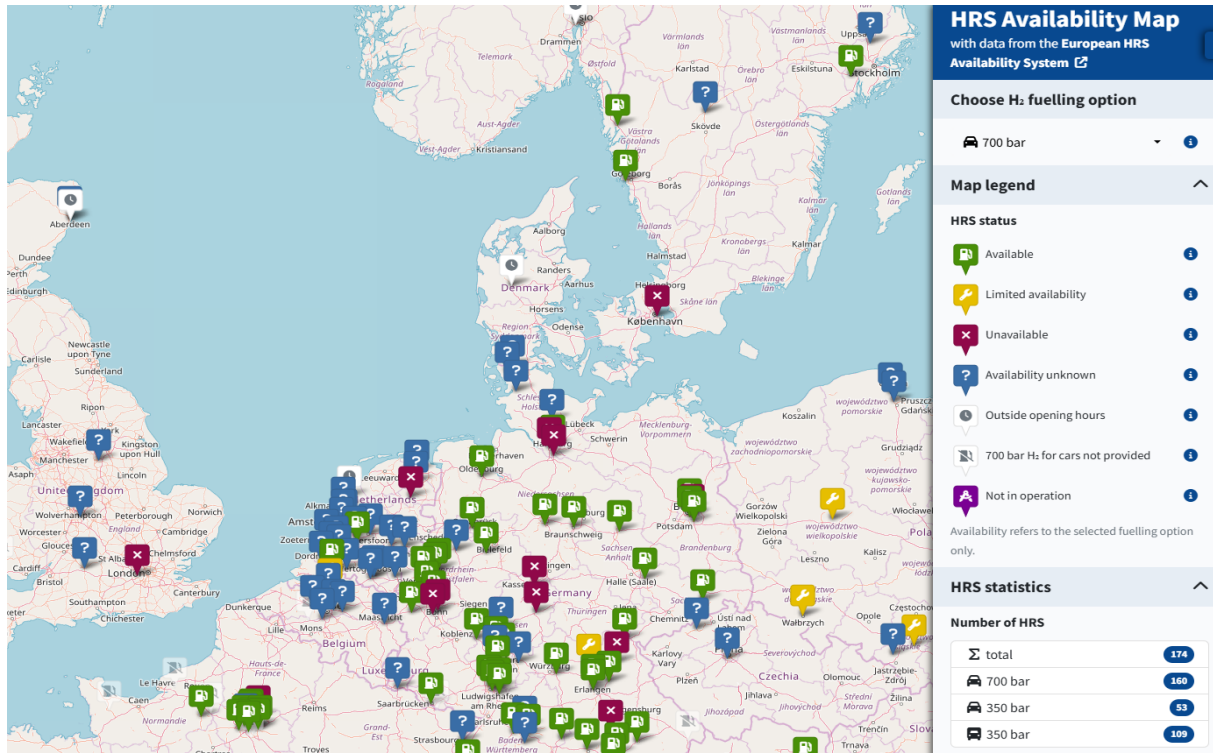
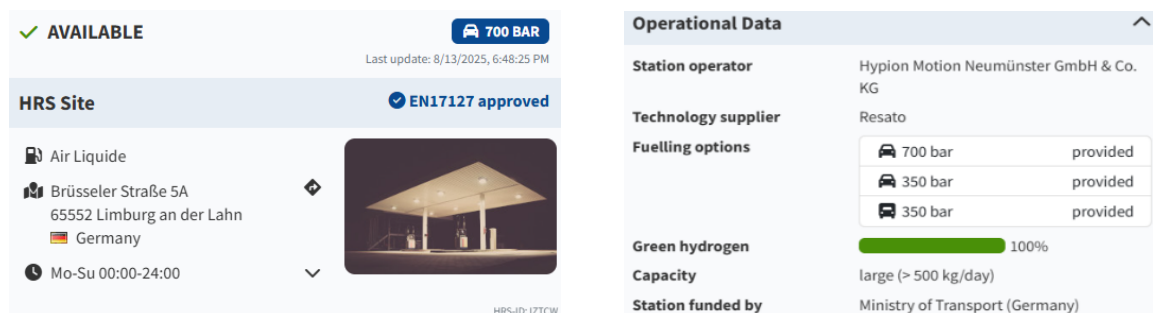

Figure 10: Interactive Map of E-HRS-AS – H₂-map

The H₂-map provides detail on each station specification, such as station operational data and fuelling option as seen on Figure 11. Some stations are not operating 24 hours a day, so drivers are advised to estimate their arriving time accordingly. The sustainability indicator of fuel sourcing is also indicated, although not always presented. While the availability of fuel can be seen from the icon on the map, it does not show the latest refuelling history as what has been presented on H₂-live map previously discussed (see Figure 8). Meanwhile, the refuelling capacity is only presented as static information rather than actual remaining fuel available. In addition, information regarding refuelling requirements, accepted payment method, and vehicle authorization are available, as seen on Figure 12.



(a) Availability, operating hour, address

(b) Fuelling options, station operator, maximum capacity

Figure 11 HRS operational information

Refuelling requirements	
Access	Tyczka Hydrogen Card, BayWa Card or H2 Mobility registration needed. The HRS is available for 350 bar trucks, 700 bar trucks and 700 bar cars.
Authorization	H2.LIVE/CARD
Payment	Invoice via H2.LIVE/CARD

Figure 12 More details on access and payment option

3.2.2. European hydrogen observatory - [Geomap](#)

European hydrogen observatory is an open platform providing latest information about Europe’s hydrogen sector. It is an initiative promoted by the Clean Hydrogen Partnership as part of the grand vision to scale up the development of sustainable hydrogen technologies. The platform brings together information on hydrogen production process, pipelines, end-consume usage, and refuelling station across Europe. This dashboard provides transparency over hydrogen market, especially in relation to green hydrogen value chain, as seen on Figure 13.

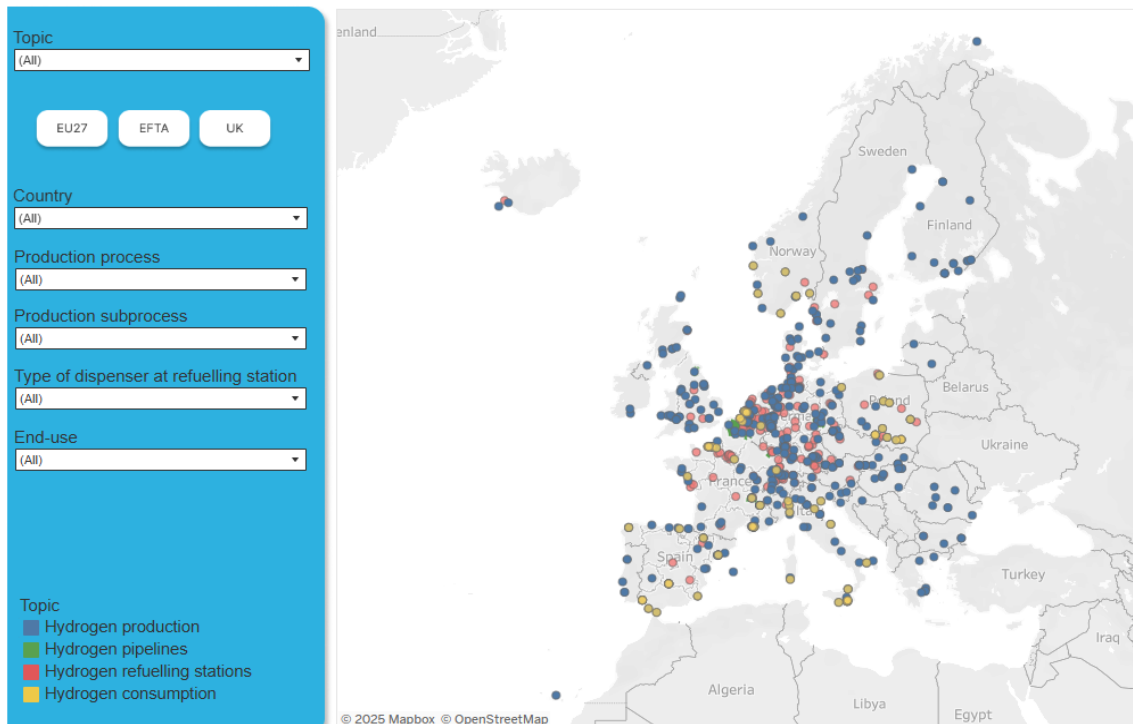
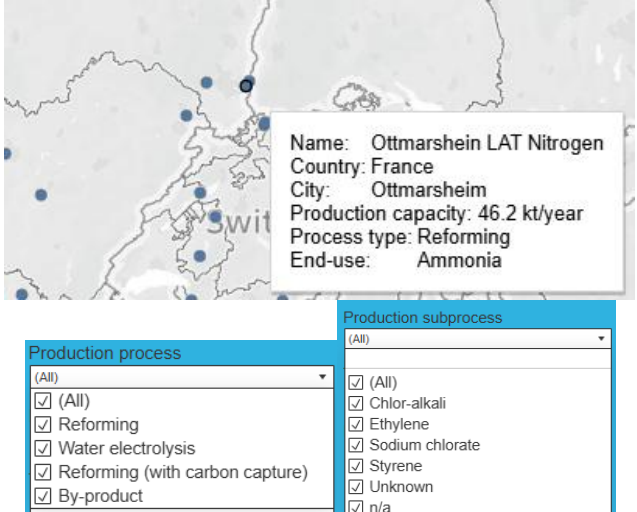
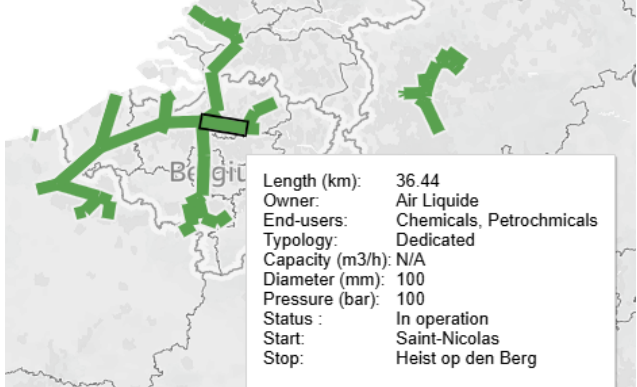
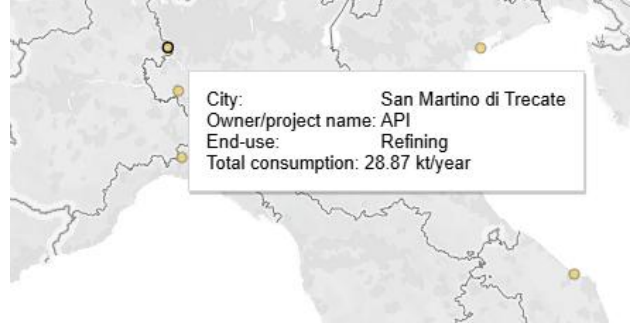
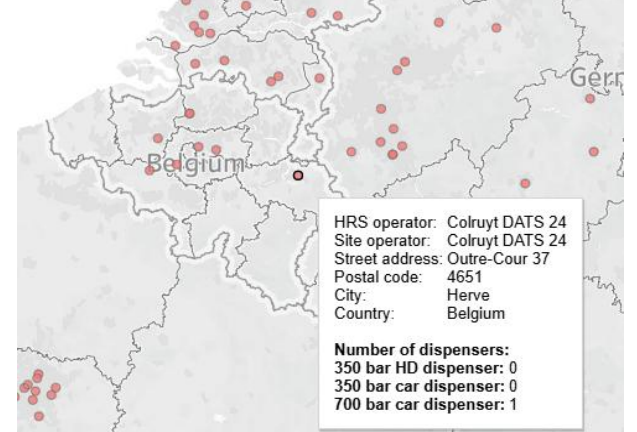

Figure 13: European hydrogen observatory infrastructure map

Table 2 depicts each of the element's present in the dashboard: hydrogen production plants, distribution pipelines, consumers of hydrogen and HRS (European Hydrogen Observatory, 2025).

Table 2: The different elements in the dashboard of the European Hydrogen Observatory

Topic	Illustration
<p>The map locates hydrogen <u>production plants</u> in Europe with detail information on capacity, process type, and end-use.</p>	
<p>The dashboard also features <u>hydrogen distribution pipelines</u>. The information presented are rather descriptive to visualize the size and capacity of the distribution pipelines.</p>	
<p>Facilities consuming hydrogen are also part of the dashboard. The plants are categorized into four major group: refining, ammonia, methanol, and another chemical. In October 2025, information is only provided by six countries: France, Italy, Netherlands, Norway, Poland and Spain.</p>	
<p><u>HRS</u> database is also available in this dashboard. It contains static data such as operator, address, and number of dispensers. The dashboard features a filter of type of dispenser including 350 bars for HDVs (no 700bar). However, this mapping aims for statistical purposes rather than HRS locator as operational data and other dynamic variable are absent.</p>	

3.3. European Alternative Fuels Observatory – [TENtec map](#)

The European Alternative Fuels Observatory (EAFO) serves as the main reference for information regarding alternative fuels development in Europe, including vehicles, infrastructure, legislation, and public incentives. The data are sourced from various entities including national authorities, operators, and other relevant third parties like the previously mentioned European hydrogen observatory. EAFO has been a supporting tool for the European Commission to track and assess the progress of alternative fuels infrastructure development on road transport along the TEN-T corridor.

Under alternative fuels directive, the milestone has been divided into three stages: transitional, zero-emission vehicles, and renewable fuels. Here hydrogen, alongside with electricity and ammonia belong to the second group.

[TENtec interactive map](#) is an integrated information system that contain a comprehensive overview of alternative fuels infrastructure, including hydrogen, in the EU and neighbouring countries. The database also includes statistics on alternative fuel fleets and their growth (new registration), allowing identification of infrastructure gap analysis, as shown in Figure 14. Furthermore, the platform also offers market-related insights such as charging price, recent vehicle models, etc.

The dashboard for infrastructure presents general information on the operating company, address, and type and number of available dispensers. Users may select the data shown based on countries, cities, and type of dispenser. The database is updated regularly, though not in real-time. The website claim that the data will be updates on the 15th of each month.

The visualization compiles several metrics useful to analyse the progress towards H₂ fuel for road transport expansion (European Alternative Fuels Observatory, 2025). Figure 14 (a) presents general statistics on refuelling points by country, using relative colour coding to support comparative analysis and highlight which countries have a higher number of stations. However, when assessing the reliability of HRS infrastructure, absolute numbers alone are insufficient. It is therefore important to examine additional metrics provided.

Figure 14 (b) shows the year-on-year (YoY) growth of HRS, indicating whether infrastructure is expanding. Notably, the scale includes negative values, revealing that some countries have experienced station closures. Combined with the absolute number of HRS, this metric helps forecast infrastructure development trends in each country.

The next metric relates to the reliability dimension, showing the number of FCEVs per HRS (Figure 14 (c)), which may indicate the capacity of supporting infrastructure to meet hydrogen refuelling demand. While other reliability metrics are more relevant during the early rollout phase, such as the proximity of HRS to strategic TEN-T corridors or the distance between stations as highlighted in AFIR (see Chapter 2.3). This indicator is useful for anticipating future HD-FCEV growth and ensuring infrastructure keeps pace with rising demand.

Figure 14 (d) presents the year-on-year growth of HD-FCEVs by country, though data availability is limited to a few countries. This metric can support HRS operators in planning infrastructure expansion and justifying future investments. Although HD-FCEV growth has not yet been significant, these vehicles are being demonstrated in use cases where electrification faces challenges, as noted on the EAFO website. In the initial phase, hydrogen adoption is expected in captive applications such as city buses, commercial fleets (e.g., taxis), and specific segments of the rail network. One example is the deployment of hydrogen fuel-cell trains to replace diesel operations on tracks where electrification is economically unfeasible.

The organization also promotes alternative fuel adoption beyond land transport, including maritime and inland waterways. Chapter 6.3 will presents past and on-going research projects aimed at scaling up electrolysis capacity from renewable sources, with a focus on captive users such as urban transport buses and refuse trucks.

H2 refuelling points

Total number of hydrogen (H2) refuelling points

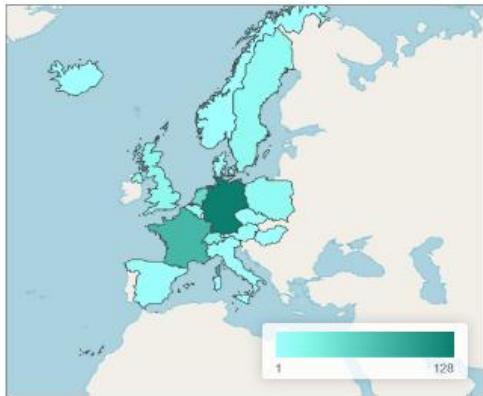

a) Number of HRS per country
H2 vehicles per H2 refuelling point

Number of hydrogen (H2) vehicles per hydrogen refuelling point (high and low pressure).

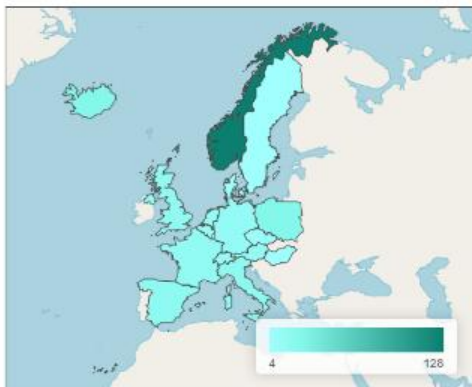

c) Ratio of FC trucks per HRS

Growth rate of H2 refuelling points

Year-over-year (2024 vs. 2023) growth rate of hydrogen (H2) refuelling points.

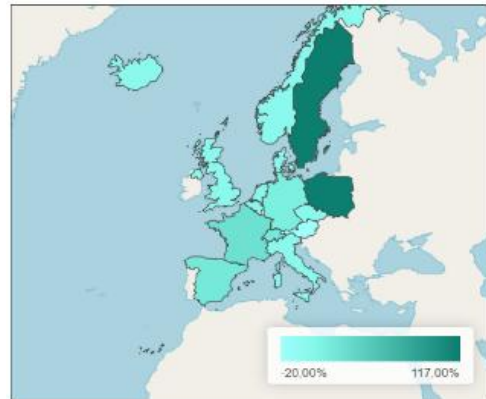

b) Annual growth of HRS
Growth rate H2 trucks

Year-over-year growth rate of the hydrogen (H2) trucks (N2+N3) fleet.

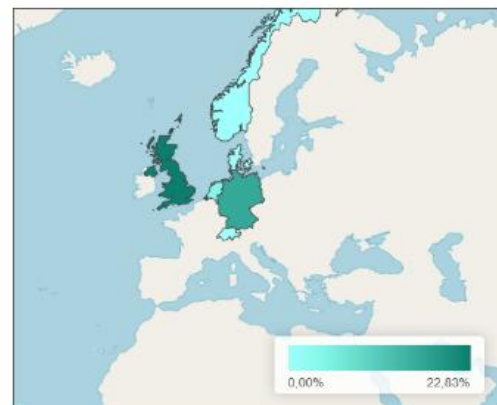

d) Annual growth of registered FC trucks

Figure 14 : Statistic figure of alternative fuel vehicles

TENtec also provides an interactive map which locates the specific infrastructure as seen on Figure 15 (TENtec, 2025). The map features customisable layers that allow users to visualise a combination of specific route, corridor, alternative fuel types, and nodes.

In the context of ZEFES, this combination allows to assess the availability of HRS on each corridor, as seen on the map. The station specification is also presented, highlighting the capacity, pressure, and fuel sustainability indicator as seen on Figure 16. However, this map does not show the real-time status of the station availability and opening hours.

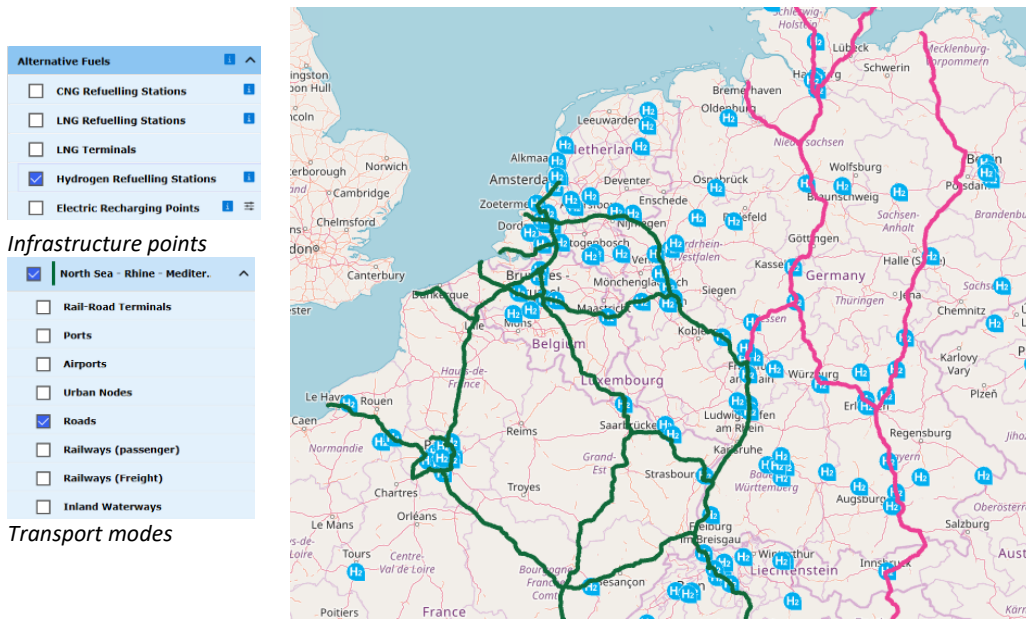

Figure 15: Visualisation of the [TENtec interactive map](#)

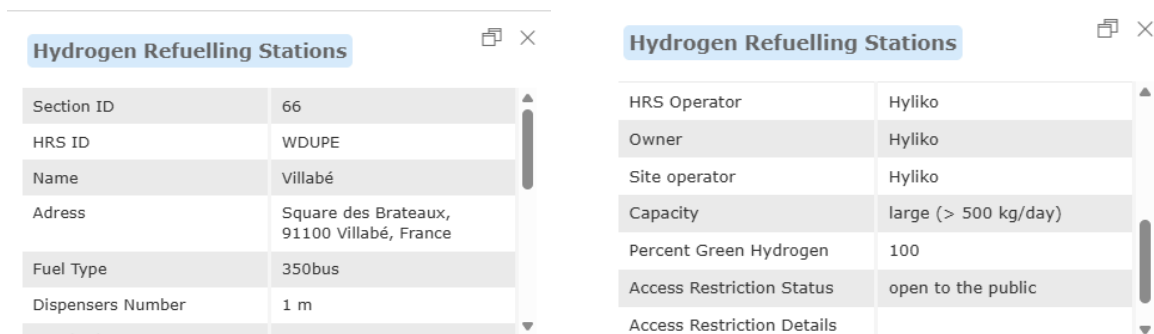
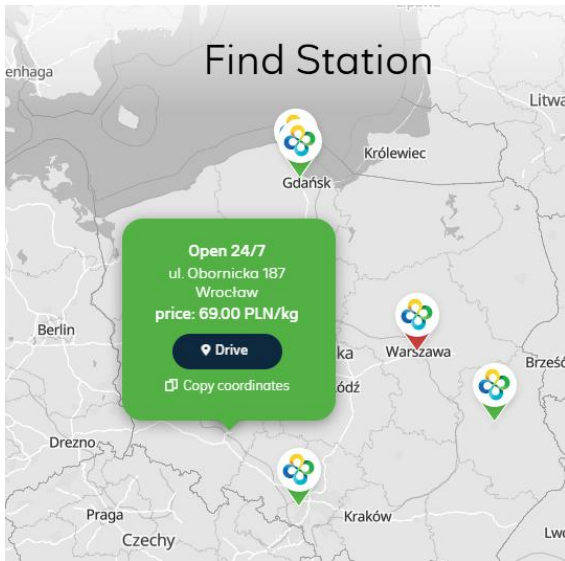

Figure 16 Information on HRS operations

3.4. Regional maps and maps of HRS operators

Several station operators have also developed their own locator map that shows operational status. Figure 17 (a) illustrates an example of operator's own map by Neso in Poland. The platform visualises the hydrogen price while also claiming that the current price is published on the European Institute of Public Administration (EIPA) website. Similarly, Hydrospider, a Swiss company that produce and distribute hydrogen to various station operators has launched its own map of own filling stations. In addition to the station locator, the platform also displays the HRS operational status in a list-style table, making it easy for users to assess available refuelling options as seen on Figure 17 (b). However, the map does not provide real-time fuel pricing.



(a) HRS locator in Poland (Neso, 2025).

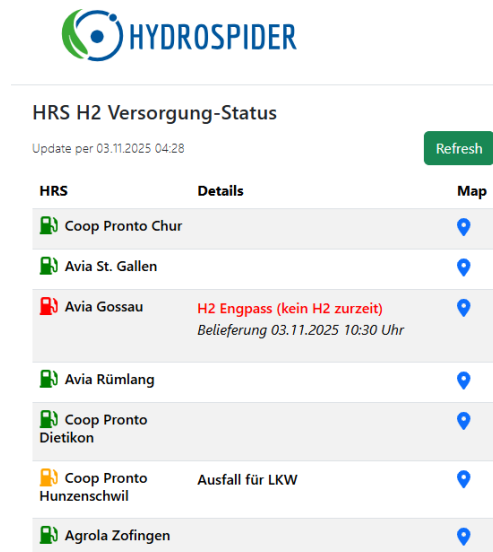

(b) HRS locator in Switzerland (Hydrospider, 2025)

Figure 17 Company's own HRS locator map

Another example of mapping comes from a national research initiative. *L'observatoire de l'hydrogène* in collaboration with *France Hydrogène* organisation, has developed a database of hydrogen infrastructure projects, including refuelling stations (L'observatoire de l'hydrogène, 2025). As shown in Figure 18, the platform includes a vehicle type filter, a feature not commonly found in other maps. However, it lacks detailed operational information such as station opening hours, accepted payment methods, and fuel prices. This suggests that the platform is primarily designed as a strategic database rather than a practical tool for operational planning. Meanwhile, the existence of other hydrogen infrastructure projects which can be overlay on the same mapping may indicate the potential corridor for future hydrogen station expansion, considering the integration with production plant and the proximity with other hydrogen use cases to realise an efficient green hydrogen ecosystem.

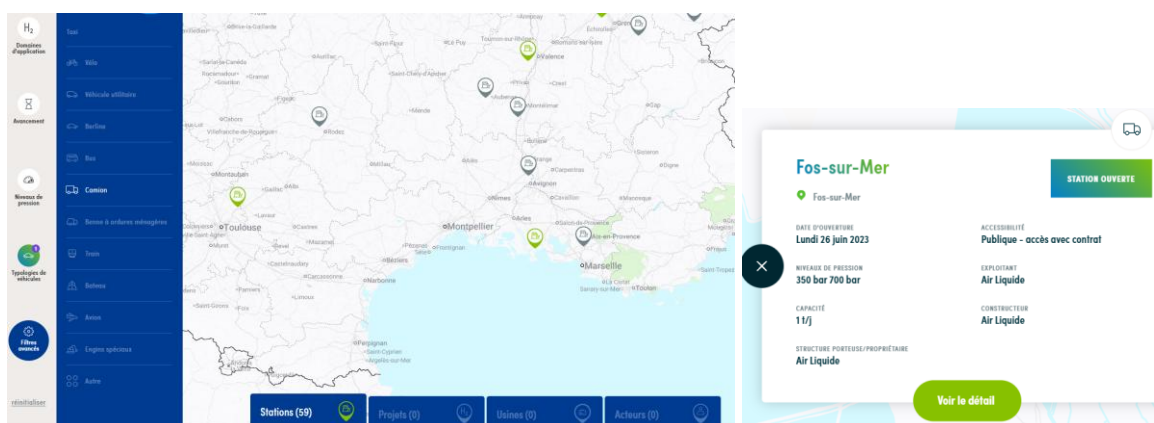

Figure 18 Hydrogen infrastructure by France Hydrogène

3.5. Discussions with HRS operators

In ZEFES, three HD-FCEVs will operate on different use cases throughout Europe. The trucks were planned to operate in Spain, Sweden, Austria, Italy and Turkey, with mitigation options in Germany, Belgium, Luxembourg and the Netherlands. The consortium partners reached out to HRS operators active in those countries. In Austria and Sweden, suitable HRS along the ZEFES corridors were found and the operators were contacted to discuss the usage of the HRS. Accessibility of the HRS for trucks, operating pressure, nozzle type, fuelling protocols, amount of hydrogen that can be refuelled were discussed, and the HRS were found usable for the ZEFES UCs. Nevertheless in 2025, the news that OMV closed their HRS in Austria and Hynion in Sweden went bankrupt were received by the ZEFES consortium. This meant that the Austrian UC cannot go through as initially planned, and mitigation options are currently investigated. For the UC in Sweden alternative HRS were found.

In Italy, the operational HRS were not located close enough to the ZEFES use cases to ensure reliable hydrogen supply. Initially, the metropolitan areas of Milan and Rome were identified as potential cluster locations, and contacts were established with HRS developers. However, due to infrastructure limitations, a mitigation plan was developed for one of the Italian use cases. While the starting point of the use case remained unchanged, the endpoint was shifted to Germany. This adjustment expanded the scope of the mapping exercise to include Germany and Switzerland.

In Spain and Turkey, the same story unfolded. HRS operators were contacted, investment and funding plans were drafted, together with mitigation plans. Several mitigation options, such as the temporary installation of mobile refuelling stations, or the collaboration with other projects were discussed. Also, the mitigation option to move the UC to the Benelux region, is assessed. The ZEFES consortium is currently defining the UC further and establishing contact with HRS operators in Belgium, Netherlands and Germany.

In conclusion, the maps of operational HRS are useful to find refuelling locations. Nevertheless, in most cases truck operators need to contact the HRS operators to check the accessibility and the technical specification of the HRS further. Also, the existing network of European HRS for heavy-duty vehicles is not sufficient to support long-haul logistics. The requirements stated by the AFIR regulations (see section 2.3), are not met. When the ZEFES project proposal was developed, it was assumed that HRS funded through national and European programmes would be operational by 2025–2026. This assumption has not materialized, and as a result, the ZEFES use cases must now be adapted to reflect the current infrastructure reality.

4. Mapped infrastructure along the TEN-T corridor

The ZEFES project aims to demonstrate the viability of HD-FCEVs for long-haul logistics missions. As a stepping stone, several strategic routes along the TEN-T corridor will be selected to showcase HD-FCEV applications. Assessing the readiness of HRS infrastructure is therefore essential. This work has explored potential stations along these routes that are accessible to HD-FCEVs. Table 3 summarizes the findings, including the number of stations currently non-operational (status of November 2025) as well as those under construction.

Table 3 Mapping of HRS along the original UC demonstration routes

Use Case	Routes	N° Public HRS				700 bars for HDV presents?
		Ready to use	Opening soon	On planning or approval	Closed	
721	VOLVO Gothenburg SE - Hofors, SE	3				No
732	Brenner corridor Italy to Austria	4	1	1		Yes*
733	Murcia, Spain - Le Boulou, France					
761	Ford Focaeli Plant to Istanbul Pendik Ports					
762	Graz to Vienna, Austria - Bratislava, SK				2	Yes
763	Gattatico IT to Crailsheim DE (via Austria)	3	2			No

**) Status of Nov 25, an HRS with 700 bar compatible for HDV is in the final construction phase*

To support visualization of HRS locations along the selected routes, a custom map has been developed. It includes annotations for both operational and soon-to-open stations. Access the map here: [ZEFES HRS mapping](#).

4.1. Italy to Germany

Initially two HD-FCEV UC were planned in Italy. Nevertheless, during the preparation of the UC, mitigation actions were taken, as explained in Section 3.5. Therefore, also HRS in Switzerland and Germany are mapped.

Italy and Germany own several major manufacturing and logistics clusters where significant freight volume is flowing regularly. There are two possible routes that connect the two countries, one pass through the Brenner Pass, a critical corridor of road freight logistics connecting Italy to Austria, with a critical route section from Brixen to the Brenner Corridor (Highway A22). The second option is through Switzerland. Along these routes, there has been few established HRS compatible with HD-FCEV, with some HRS planned to open. It is worthwhile to discuss the adequacy of HRS infrastructure by comparing these two alternatives.

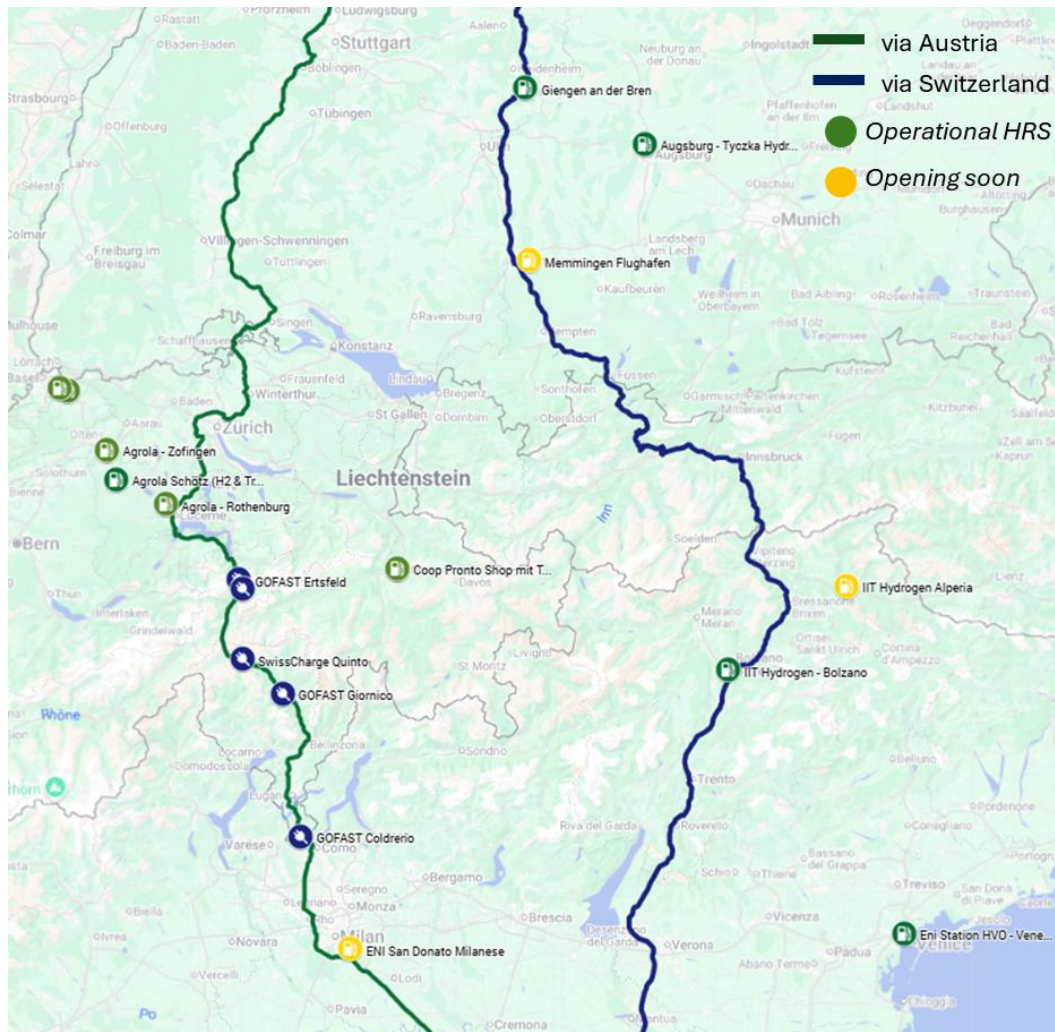

Figure 19: Italy to Germany corridor

On the Italian side, there has been few HRS built with other being constructed. Two example features a station close to Venice and Milan, which offers a great potential as they are close to the country's industrial area and main logistics hub. In November 2025, an HRS is currently under construction in Verona Nord, close to Italy A4 highway, a strategic route which spans across the country's main industrial cluster from Turin to Trieste. The station is designed to dispense up to 3500 kg of hydrogen daily, equivalent to 200 LDV and 70 HDV. The development is part of the "Zero Emission Services for a Decarbonised Alpine Economy" (LIFEalps) project which is expected to be operational by mid-2026. This HRS can strengthen the infrastructure on Italy-Austria corridor as it will be located close to Highway A22 Autostrada del Brennero.

Table 4 HRS Infrastructure around depot (IT – DE)

Location reference	Closest HRS	Pressure	Status
Start-Italy	Verona Nord		Opening in mid-2026
	ENI San Donato Milanese	700 bar + 350 bar (HDVs)	In optimisation phase
End-Germany	Giengen an der Brenz	700 bar + 350 bar	In optimization phase. 350 bar ready for use
	Tyczka Hydrogen GVZ Augsburg	700 bar + 350 bar	Ready

Fout! Verwijzingsbron niet gevonden. presents the HRS available along the demonstration route, assuming a delivery trip from Italy to Germany.

Table 5 HRS Infrastructure density Italy to Germany corridor

Route	HRS	Pressure	Status
Via Austria	IIT Hydrogen Bolzano	700 bar + 350 bar (HDVs)	Ready
	IIT Hydrogen Alperia	700 bar + 350 bar (HDVs)	Opening in Q4 2025
	Memmingen Flughafen	700 bar + 350 bar	Opening in Q4 2025
	Tyczka Hydrogen GVZ Augsburg	700 bar + 350 bar	Ready
Via Switzerland	Agrola Rotherburg	700 bar + 350 bar (HDVs)	Ready
	Agrola Schötz	700 bar + 350 bar (HDVs)	Ready

As the route progresses through Austria, the truck will pass through an HRS at IIT Hydrogen Bolzano. This facility is situated next to A22/E45 exit, easily accessible through the toll ramps without major detour. Another facility is currently under construction, located in Bruneck along SS49. Once open in Q4 2025, it may serve as an alternative refuelling station reachable from Brenner corridor while also allowing drivers to choose which facility that suits better their break time. Meanwhile, there are 2 other HRS approaching the end destination.

The Switzerland route currently offers more operational HRS suitable for HDVs, with five accessible stations, most of which are strategically located near highway exits. In terms of HRS density, the corridor in Switzerland offers more alternatives within shorter distance, less than 100 km. Along the route toward Germany, one HRS is available in Rothenburg, Switzerland. Meanwhile, there is another alternative within 30 km at Schötz. There are four other HRS in Switzerland on the direction to Basel, which also connected to France. Continuing to Germany, in November 2025, there are no HRS compatible for HDVs within the proximity of highway. While a few stations exist around Stuttgart, they currently serve only light-duty vehicles (LDVs).

In Figure 19, some charging points along the route are also mapped, since CCS charging can be a mitigation action in case of hydrogen runout. These charging hubs are located on highway service area, accessible and easy to locate for emergency recharge. Some HD-FCEVs are equipped with a CCS2 connector and a proper battery pack. Charging HD-FCEV can be a last resort to reach the destination.

4.2. Sweden

This corridor represents an integration of HD-FCEV into multimodal hubs where road transport connects logistics cluster to the intermodal terminal. Port of Gothenburg has been selected as the strategic logistics nodes where flow of goods in and out of the country started (**Fout! Verwijzingsbron niet gevonden.**). Going deep into the country, there are two HRS identified. The first one is in Port of Gothenburg, which represent a strategic infrastructure placement on starting point. Another station is situated at Mariestad is located close to the highway exit. The distance between these two consecutive stations is around 180 km, which comply with the AFIR recommendation of HRS infrastructure density. This serves as a good example of the early HRS infrastructure expansion, where it enhances both accessibility and reliability of hydrogen refuelling.

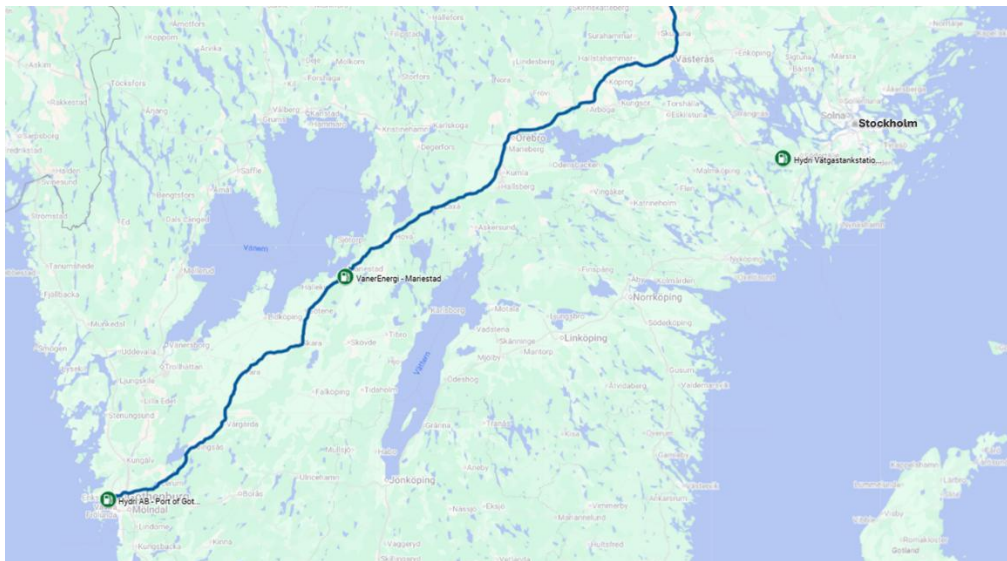

Figure 20: Swedish corridor

Several HRS are opening along this corridor, including a station in Nykvarn operated by Hydri AB, which currently supports 350-bar refuelling for HD-FCEVs. The company states that the site is primarily designed for heavy-duty vehicles, while remaining accessible to passenger cars (Hydri, 2025). In November 2025, the 700-bar dispenser is still under commissioning. The station is located near European route E2, a strategic corridor connecting Malmö to Stockholm via Gothenburg, and forms part of the Scandinavian–Mediterranean TEN-T network. With more HRS deployed along this route, ideally spaced no more than 200 km apart in line with AFIR guidelines, the corridor will become increasingly viable for HD-FCEV operations. Additional stations could be located at intermodal terminals or near Stockholm port, following the model established in Gothenburg.

Table 6 HRS infrastructure mapped for UC Sweden

HRS	Pressure	Status
VanerEnergi Mariestad	700 bar	Ready
Hydri AB - Port of Gothenburg	700 bar + 350 bar (HDVs)	Ready
Hydri AB - Nykvarn	350 bar (HDVs) 700 bar (in commissioning)	Ready

4.3. Benelux and Germany

The Benelux region is home to some of Europe’s key logistics hubs and ports, making it a strategic corridor with strong potential for logistics decarbonisation. Its network of established medium-to long-distance routes offers promising economies of scale for expanding HRS infrastructure. Its proximity to the extremely dense industrial regions like Rotterdam to Normandy and then a triangle going to the Rhine-Ruhr in Germany are sweet spots that can accelerate the development of the market.

This work has explored the feasibility of deploying HD-FCEV along routes from Belgium to Germany’s North Rhine region, where several HRS locations have already been established, as illustrated in Figure 21.

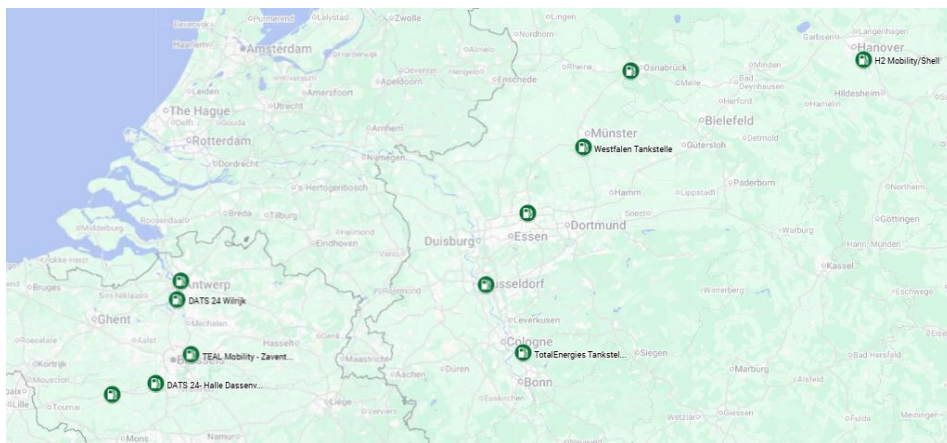

Figure 21 HRS in Benelux - North Rhine

Most HRS are located near highways, with some also positioned within industrial clusters or intermodal terminals, making them suitable as starting points for logistics routes. However, as of November 2025, these facilities typically support 350 bars dispensing for heavy-duty vehicles. A limited number are equipped with 700 bar dispensers, but these are currently only compatible with passenger cars, not HDVs as presented on Table 7.

Table 7 HRS in Benelux to Germany

HRS on route	Pressure	Availability
CMB.Tech – Mexicostraat Antwerp, Belgium	350 bar (HDVs)	Semi-public
TEAL Mobility – Zaventem, Belgium	350 bar (HDVs)	Ready
DATS 24 Halle Dassenveld, Belgium	700 bar (passenger car)	Ready
DATS 24 Lessines, Belgium	350 bar (HDVs and passenger cars)	Ready
DATS 24 Wilrijk, Belgium	700 bar + 350 bar (HDVs)	Ready
H2 MOBILITY/TotalEnergies Köln, Germany	700 bar + 350 bar (HDVs)	Ready
H2 MOBILITY Düsseldorf, Germany	700 bar + 500 bar + 350 bar (HDVs)	Ready
H2 MOBILITY – Herten, Germany	700 bar + 350 bar (HDVs)	Ready
Westfalen AG Münster, Germany	700 bar + 350 bar (HDVs)	Ready
H2 MOBILITY/Shell – Laatzten, Germany	700 bar + 350 bar (HDVs)	Ready
H2 MOBILITY/TotalEnergies - Hasbergen, Germany	700 bar + 350 bar (HDVs)	Ready
H2 MOBILITY/Shell - Hamburg, Germany	700 bar + 350 bar (HDVs)	Ready
Hypion H2 - Neumünster, Germany	700 bar + 350 bar (HDVs)	Ready

4.4. Spain

This Mediterranean TEN-T corridor facilitates the import and export of goods from Spain to other parts of Europe, particularly the transportation of agricultural products from farmers and producers to retailers. It serves as a strong example of diverse business cases for decarbonisation. The main flow follows a highway route to the French border, connecting numerous industrial clusters via the Autopista Mediterráneo and intersecting with the intermodal terminal in Le Boulou, France.

In November 2025, there are no operational HRS along this corridor that are accessible and compatible with HD-FCEV.

Strategic site selection, balancing high utilization potential and promising vehicle growth, is essential to ensure the business viability of HRS during the early rollout phase. On the demand side, stations could be deployed near origin and destination points, as well as along highways to support en-route refuelling. Accordingly, several locations present potential for early HRS development, as illustrated in Figure 22. For instance, in Valencia, Spain, the port terminal is deploying hydrogen for applications such as terminal tractors under the H2Ports program (Valenciaport, 2023). This creates opportunities for broader business use cases and serves as a strong example of a functioning hydrogen ecosystem. Additionally, co-locating hydrogen production facilities, especially those powered by renewable sources, can further enhance system efficiency and sustainability.

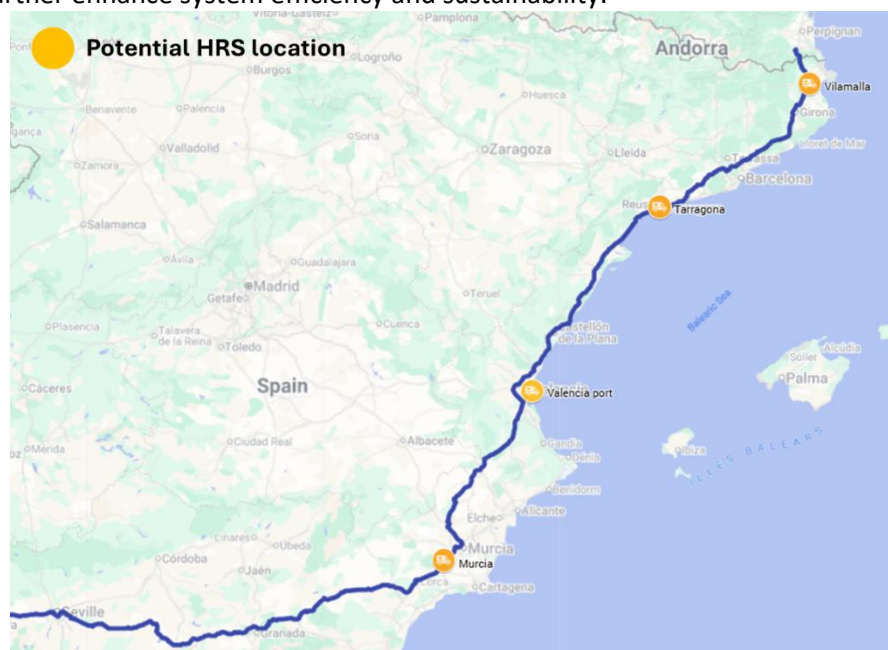

Figure 22 Potential HRS location for early development in Spain

5. Challenges and barriers on HRS deployment for long-haul logistics with HD-FCEV

The mapping of available and suitable HRS for HD-FCEV made it clear that at the moment the European HRS network cannot sustain long-haul cross border freight logistics. The ZEFES UC needed to be limited or altered, due to HRS availability. In this Chapter, the challenges on HRS deployment, encountered by the ZEFES consortium are listed. Reasons as limited technology readiness (for both truck and HRS), the availability of renewable hydrogen and economic viability of HRS were all mentioned during the search for HRS, as reasons why HRS projects are not completed.

5.1. Limited technological readiness

The technology and design of both HRS and HD-FCEV are evolving to reach more performant assets. For example, increasing FCE-HDV driving range is crucial, to serve long-haul distribution routes efficiently. This could be achieved by increasing the hydrogen mass on the vehicle by increasing the operating pressure and/or the volume of the tanks or using liquid hydrogen. Another advantage of hydrogen that can be improved, is the fast-refuelling time.

However, to achieve more hydrogen mass on the vehicle and a faster refuelling time, the current technology and design of HRS and trucks need to be altered. Innovations in hydrogen storage vessels, hydrogen dispensers, standards, refuelling protocols, fuel cells, etc. are happening and the evolving technology links to an investment risk for both the HD-FCEV and HRS operators. In addition, the HRS and HD-FCEV must be compatible and interoperable.

5.2. Renewable hydrogen availability and cost

Currently, most of the hydrogen produced globally is generated using Steam Methane Reforming (SMR). SMR accounts for approximately 95% of hydrogen production worldwide, utilising natural gas as the primary feedstock. This method, while well-established and cost-effective, results in significant carbon dioxide emissions unless combined with carbon capture and storage technologies. In contrast, renewable hydrogen production via electrolysis represents a much smaller share of the overall market but is expected to grow as decarbonisation efforts intensify. Production by electrolysis is a well-established method that involves splitting water into hydrogen and oxygen using electricity, with the process's sustainability largely depending on the source of electricity.

Renewable, or green hydrogen, as defined by the outcomes of the CertifHy project is hydrogen produced through the electrolysis of water using electricity derived exclusively from renewable energy sources (Certifhy, 2024). This means that the entire electricity input must be verified as originating from renewable resources such as wind, solar, or hydropower, ensuring that the hydrogen production process is virtually carbon-free. The CertifHy project also established criteria and a certification system to guarantee traceability and transparency for green hydrogen, allowing end-users to distinguish it from hydrogen produced through fossil-based methods.

As highlighted in the Alternative Fuels Infrastructure Regulation (AFIR), operators of publicly accessible HRS must disclose whether the hydrogen is produced using renewable sources. The challenge goes beyond that providing a reliable information, it lies in ensuring that green hydrogen is available at a

reasonable cost. Critical aspects include not only its production and distribution, but also how the business model can sustain HRS business model sustainability

5.3. Fuel quality and purity

The purity of hydrogen used in fuel cells must be high (SAE J2719 or ISO 14687). Now, the purity cannot be monitored inline. This means that potential contaminations cannot be detected at HRS level. The HRS operator need to trust the hydrogen supplier and is unable to monitor possible contaminations from the HRS components, such as the compressor. If a contamination occurs, and the HRS or vehicles are damaged, disputes about liability may arise.

5.4. Accessibility of HRS capability data

Accessibility of hydrogen refuelling infrastructure is a critical aspect to enable an optimum logistics mission carried out by HD-FCEV. Alternative Fuels Infrastructure Regulation (AFIR) has set binding requirements for the specification and procedures of data on hydrogen refuelling system across Europe through its latest implementing regulation 2025/655 (European Union, 2025). The data is categorised into two group: static and dynamic. The difference lies on the frequency of data updates, which is specified on article 2 of the regulation.

Dynamic data group comprises of HRS operational status, station occupancy, ad-hoc price, and warning of the limited amount of hydrogen fuel. According to AFIR, these information needs to be updated within one-minute timeframe. While synchronization of operational status is already available across platforms, like those used for gas and EV charging stations, accurately reporting the available quantity of dispensable hydrogen remains a challenge. These vehicles typically require over 30 kg of hydrogen for a full refuelling session, compared to 4–5 kg for light-duty vehicles (Klimafreundliche Nutzfahrzeuge, 2025). In November 2025, most HRS are still designed primarily for passenger cars, making real-time hydrogen availability data especially critical for heavy-duty trucks. During the ZEFES demonstration, hydrogen availability will be manually confirmed with station operators prior to each run, a process that would be impractical in future commercial operations.

While static data should only be updated in case of changes, which is less likely to occurs compared to the dynamic category, it mandates that information should be corrected within 24 hours. One key element of static data is the origin of hydrogen, specifically whether it is supplied through a 100% renewable value chain. In November 2025, this information is not consistently displayed across all platforms, as highlighted in chapter 3, indicating a gap in transparency that may affect user trust and regulatory compliance.

5.5. Low station utilization

The ZEFES project targets long-haul logistic routes which are currently served mainly by ICE-powered, diesel trucks. For HD-FCEV to replace existing diesel trucks, vehicle technological readiness alone is not sufficient; adequate infrastructure is equally critical, just as the availability of renewable hydrogen. The transition from diesel to hydrogen will affect the entire fuel value chain, from well to tank.

Currently there are no commercial HD-FCEV models available on the market. Most HD-FCEV are custom made, small series produced vehicles, commonly linked to subsidized demonstration projects.

Uncertainty over the future trend towards FCEV remains a challenge that hinders the expansion of HRS infrastructure. At the beginning of the ZEFES project, there was optimism that the AFIR regulation would help secure long-term infrastructure development. Austria was considered a promising location due to the presence of several HRS operated by OMV. However, the operator has decided to close their stations by September 2025 (Fuel Wells Works, 2025). Similarly, Hynion Sverige AB filed for bankruptcy in Q2 2025 (Hynion, 2025). Lack of customer demand is one of the contributing factors. The high capital expenditure (CAPEX) associated with fuel cell vehicle pricing, combined with limited hydrogen refuelling infrastructure, has hindered the competitiveness of FCEVs compared to Battery Electric Vehicles (BEVs). In a more recent development, as of October 2025, Metacon has acquired Hynion's assets and is now actively expanding its hydrogen refuelling network in Sweden (Metacon AB, 2025).

5.6. Uncertain vehicle residual value

In addition to the limited availability of commercial HD-FCEV models, factors such as high initial costs, uncertainty around maintenance requirements, and unclear residual value reduce the willingness of logistics carriers to invest in these vehicles. Due to the lack of operational experience, particularly regarding maintenance costs, operators must rely on strong assumptions and be prepared to bear the risk of underestimated investments, a challenge that is even more pronounced for SME players.

6. Solutions for HRS and HD-FCEV deployment

The successful deployment of hydrogen as a fuel for HD-FCEVs hinges on a multi-faceted approach. Key solutions include ongoing technology development, encompassing advancements in both the trucks themselves and the HRS. From the truck side, this involves progress in fuel cell technology and the possible development of hydrogen combustion engines. Also, the storage of gaseous or liquid hydrogen on the vehicle can be improved.

Innovations regarding HRS can focus on stationary hydrogen storage solutions, as well as the refinement of refuelling protocols to ensure efficiency and speed. In addition, renewable hydrogen production methods need to be scaled up to ensure emission reduction.

6.1. Important European and national organisations and funding schemes

In parallel with technological innovation, robust funding schemes are essential to support infrastructure build-out. Incentive that alleviates the high upfront investment of hydrogen infrastructure is expected to facilitate scale-up. This can be coupled with collaboration across diverse stakeholders along the entire hydrogen value chain. Such partnerships enable actors to collectively address and overcome current barriers, fostering an environment where practical and scalable hydrogen solutions can flourish. The following are some examples of funding schemes.

6.1.1. European Hydrogen bank

The European Hydrogen Bank aims to support the scaling up of the hydrogen market across Europe by facilitating investments, reducing financial risks, and bridging the gap between supply and demand (European Hydrogen Observatory, 2025). Its overarching goal is to accelerate the deployment of renewable hydrogen projects and unlock private investment into the hydrogen value chain. Launched in March 2023, it offers two financing mechanisms based on the location of hydrogen production: domestic (within EU) or international (to accommodate imports from overseas).

The domestic funding scheme is designed to stimulate supply of renewable hydrogen by reducing the cost-cap relative to fossil fuel-based, while also mitigating project risk. The funding targets electrolysis deployment with minimum capacity of 5 MW. Producers may bid for a fixed-price premium of up to €4 per kilogram of hydrogen produced over 10 years. Whereas the overseas scheme aims to support partner countries toward emission reduction, which currently still being formulated. The proposed model involves a joint purchasing mechanism with EU member states, operating on a voluntary basis according to the national needs, while maintaining confidential pricing.

6.1.2. Clean Hydrogen Partnership

The Clean Hydrogen Partnership is a European initiative dedicated to advancing research and innovation in hydrogen technologies (Clean Hydrogen Partnership, 2025). It brings together industry, research organisations, and public bodies to accelerate the development and deployment of clean hydrogen solutions. As a public private partnership, it has funded several projects that have led to significant breakthroughs in fuel cell efficiency, the deployment of hydrogen refuelling stations, and the integration of hydrogen into transport and energy systems. Its work supports the EU's climate

ambitions by fostering collaboration and delivering practical, scalable hydrogen infrastructure and applications.

This program has given rise to a wide portfolio of remarkable renewable hydrogen projects, not limited to electrolyser scale up. For example, the Hydrogen Valleys project in the Netherland integrates activities up to downstream value chain, from production to end-use. Projects like FLEX4H2 and HELIOS are developing advanced combustor technologies to address key challenges such as flame stability in hydrogen-based electricity generation. Furthermore, the program also supports the transportation sector, fostering the development of fuel cell vehicles and enhancing their performance to make them competitive alternatives to fossil-fuel based vehicle. Related initiatives include IMMORTAL and DOPLHIN, which focus on advancing membrane electrode assembly (MEA) technology.

6.1.3. Hydrogen Europe

Hydrogen Europe is a leading industry association representing companies and stakeholders in the hydrogen sector. The organisation advocates for the development and deployment of clean hydrogen technologies across Europe, promoting innovation, sustainability, and collaboration within the hydrogen ecosystem. It also involves in policy analysis, public consultation, and actively organises events that tackle problems within the realization of clean hydrogen. For example, the annual Hydrogen Week, a flagship event bringing together stakeholders from across the hydrogen value chain. This organisation also partners with Hydrogen Europe Research; a non-profit association composed of universities and research & technology organisations, while actively engages with the Clean Hydrogen Partnership to secure funding support. (Project website: <https://hydrogeneurope.eu/>)

6.1.4. National hydrogen associations

The development of hydrogen is actively promoted on regional and national level through dedicated associations. In Germany, the Bund der Wasserstoffregionen (BdWR – National Hydrogen Regions Association), aims to strengthen the regional perspective within the national hydrogen strategy by coordinating 19 hydrogen regions and fostering decentralized implementation. This direction includes research project on refuelling and infrastructure components developments (NOW GmbH, 2025).

In Spain, Asociación Española del Hidrógeno (AeH2) plays a pivotal role in promoting hydrogen technologies as energy vector and its utilization in industrial and commercial applications. The organization bridges diverse actors from companies, universities, and research institutions. It actively supports research projects, infrastructure development, and legislation that drives hydrogen and fuel cell technologies. One of the projects is Green Hysland in Mallorca, aiming to deliver renewable hydrogen produced by PEM (Proton-Exchange Membrane) for multi-purpose including transport, cement plant, building energy, and tourism through refuelling stations and pipelines.

(Project website: <https://aeh2.org/en/the-aeh2/>, <https://greenhysland.eu/mallorca/lloseta-green-h2-plant/>)

Meanwhile, Italy's H2IT (Associazione Italiana Idrogeno) brings together industry and research institutions to advance hydrogen technologies, advocate infrastructure deployment, and contribute to European projects with focus on mobility applications. (Project website: <https://www.h2it.it/chisiamo/>)

The efforts toward green hydrogen realisation have gone beyond national border. Waterstofnet is a non-profit organisation that supports the development of hydrogen projects in the Benelux region. It unites industry, research, and government stakeholders to accelerate innovation and promote cross-border collaboration to facilitate hydrogen infrastructure deployment. The organisation is also actively involved in policy advocacy and serve as knowledge platform to foster hydrogen visions. (*Project website: <https://www.waterstofnet.eu/en/home/about-waterstofnet>*)

6.2. European and national funding for HRS

The Alternative Fuels Infrastructure Regulation (AFIR) sets out clear legal requirements for the deployment of HRS along the Trans-European Transport Network (TEN-T). AFIR mandates a minimum density and technical specification for HRS to ensure interoperability and accessibility for HD-FCEV across Europe. It requires that public HRS are available at regular intervals along the core TEN-T corridors, providing reliable coverage for long-distance transport. The regulation is closely linked to the Alternative Fuels Infrastructure Facility (AFIF), a funding instrument under the Connecting Europe Facility (CEF) specifically designed to support the roll-out of alternative fuel infrastructure, including hydrogen. The Clean Transport Corridor Initiative further complements AFIR by promoting the development of integrated, sustainable transport corridors, ensuring that investments in hydrogen infrastructure are strategically aligned with broader decarbonisation and mobility goals across the EU.

CEF funding plays a crucial role in realising the objectives of AFIR and AFIF by providing financial support for the construction and upgrading of HRS along TEN-T corridors. Through targeted grants and blended finance, CEF enables public and private entities to overcome investment barriers and accelerate the deployment of hydrogen infrastructure. By linking funding to AFIR's legal framework and AFIF's dedicated facilities, the CEF ensures that resources are directed towards projects that contribute to a coherent, interoperable network of HRS, supporting the transition to zero-emission transport across Europe. This funding involves stakeholders from various member states. One example is the latest green hydrogen infrastructure project in Poland, partnering with PAK-PCE Biopaliwa i Wodór and PAK-PCE Stacje H2 (HIL, 2025). [The project](#) aims to build five public HRS along the Trans-European Transport Network (TEN-T network) and green hydrogen production facilities of 5 MW.

6.3. Projects on green hydrogen production

There have been several projects demonstrating hydrogen production process through various approaches. The early phase project mostly focused on producing hydrogen to supply a specific need, mainly to offset carbon emissions from energy-intensive industrial operation. The following depicts examples of early phase green hydrogen projects.

i. H2FUTURE (Austria):

A demonstration of green hydrogen from renewable sources of electricity, which took place at a steel manufacturing plant owned by Voestalpine in Linz, Austria. The facility features 6 MW PEM electrolyzer to produce green hydrogen for industrial applications. According to the project's dissemination, the electrolyzer has been operating since November 2019. While the demo was designed to supply green hydrogen for specifically steel production, it sets examples of decarbonization in heavy industrial processes (*project website: <https://www.h2future-project.eu/en>*).

ii. REFHYNE (Germany):

This project is funded by EU commissions and the Clean Hydrogen Partnership which began in January 2018. This project operates a 10 MW PEM electrolyser with a production output target set at 1300 tonnes of hydrogen per year. The facility is situated in Shell Rhineland Energy and supplies green hydrogen for refinery processes at Chemical Park in Wesseling. The work has demonstrated the integration of clean hydrogen with industrial energy systems. (*project website: <https://www.refhyne.eu/about/>*)

iii. Djewels (Netherlands):

A demonstration of 20 MW water electrolyser (5 x 4 MW) aiming to supply renewable hydrogen to the Dutch chemical sector. The facility is located inside Delfzijl Industrial Park which has a connection to electric transmission grid, opening further opportunities to expand hydrogen production for greater application, with plans for future expansion to 60 MW. (*project website: https://djewels.eu/?page_id=863*)

iv. Gigastack (United Kingdom):

Gigastack is a multi-phase program aiming to deploy large-scale electrolyzer to supply industrial needs. The project developed a preliminary design of 100MWe-scale electrolyser system which is integrated with Hornsea Two windfarm. The hydrogen will be supplied to a refinery that was previously powered by fuel gas.

(*project website: <https://orsted.co.uk/media/newsroom/news/2020/02/gigastack-phase-2>*)

Beyond industrial applications, green hydrogen is being demonstrated as a viable alternative fuel for transportation, a sector that significantly contributes to emissions. One notable example is H2RES project in Denmark, which showcases a 2 MW electrolyser powered by offshore wind turbine. The plant is located at a Ørsted with a daily production capacity up to 1000kg. Green hydrogen will be transported to local hydrogen deposits to supply fuel-cell vehicles, including heavy duty trucks and taxis around Copenhagen. (*project website: <https://stateofgreen.com/en/solutions/h2res-green-hydrogen-production/>*)

Furthermore, recent project has advanced toward larger-scale hydrogen production while integrating the entire value chain, from upstream renewable energy sources to downstream energy distribution, storage, and end-use applications. These initiatives show a growing commitment towards system-level development of green hydrogen. Below are a few notable examples:

i. HEAVENN (Netherlands):

A regional hydrogen development project in the Northern Netherlands, combining production, distribution, and end-use of renewable hydrogen across industry, mobility, and heating. The project aimed to create a fully integrated hydrogen value chain ecosystem powered by the available renewable energy sources on the area, both from solar and offshore wind turbines. It sets examples of how hydrogen ecosystems evolve and may be replicated in other parts of the world. (*project website: <https://heavenn.org/>*)

ii. HyDeal Ambition (Spain, France, Germany):

A large-scale initiative aiming to produce 3.6 million tonnes of renewable hydrogen per year by 2030. The project leverages the potential of solar power and extensive electrolyser across southern Europe. The project emphasized value chain integration from upstream to downstream within Europe which reduces reliance on overseas supply. (*project website: <https://www.hydeal.com/hydeal-ambition>*)

iii. North Sea Wind Power Hub (Denmark, Netherlands, Germany):

A cross-border vision to harness offshore wind for large-scale hydrogen production via electrolysis, enhancing energy security and grid flexibility. The project proposed a concept of hub-and spoke energy grid configuration where there will be connection from wind farms to multiple countries.

(project website: <https://northseawindpowerhub.eu/key-concepts>)

6.4. European and national demonstration projects of heavy-duty vehicles

This section highlights several relevant European projects that have demonstrated heavy-duty vehicles, including buses, refuse trucks, and freight trucks, with a particular focus on how the supporting infrastructure was implemented for each demonstration. Overall, these projects reveal that the development of both vehicles and infrastructure has progressed more slowly than initially anticipated. In many cases, timelines have been extended by several years, underscoring the complexity and challenges of deploying FCEV.

6.4.1. JIVE and JIVE2 - Bus demonstration projects

The JIVE and JIVE2 projects deployed over 300 hydrogen fuel cell buses across 22 European cities, including London, Cologne, and Groningen. These buses operated in real-world public transport networks, showcasing zero-emission mobility. Refuelling was carried out at dedicated hydrogen refuelling stations established within participating cities, supporting reliable daily operations and demonstrating the feasibility of large-scale hydrogen bus deployment in urban environments. In February 2025, 242 buses remain in active service across 15 cities with more demonstration on the coming period (JIVE 2, 2025).

According to the latest deliverable report published in 2025, infrastructure availability continues to pose challenges. The project suggests implementing shared HRS models, which is accessible to both buses and other vehicle types, may offer solution where limited depot space hinder the installation of HRS. This infrastructure may also serve HD-FCEV as it also requires large station bay and turnaround. Another challenge highlighted on the scale-up of hydrogen fuel-cell buses (FCEB) is the higher TCO compared to other alternative such as Battery Electric Buses (BEBs). The findings suggest that FCEB offer advantages in area with long route, harsh climate conditions, or limited grid capacity. The bus operators reported consistent fuel usage while operating in 5–20°C, as the heat generated by the fuel cell provides heating to the passenger cabin. While cabin heating does not account for significant energy consumption in trucks compared to FCEBs, this suggests the ZEFES project to test multiple use cases across diverse variable, especially climate, to understand where HD-FCEVs are more energy efficient and suitable than HD-BEVs.

Project website: <https://www.fuelcellbuses.eu/projects/jive-2>

6.4.2. REVIVE project

The revive project deployed hydrogen-powered refuse trucks across seven European cities covering the Netherland, Belgium, and Sweden. (manufacturer, and type of trucks). One of the pilot studies is carried out in Antwerp where two trucks have been operating since 2022, collecting garbage from the neighbourhood area. The trucks are equipped with 15 kg tanks capacity whereas refuelling takes place at DATS 24 HRS and CMB TECH in the port of Antwerp, adequate to cover the whole daily trip with

one-time refuelling. This solution enables low-noise and zero-emission waste collection, which translate into better air quality for both local communities and waste collectors (REVIVE, 2025).

On their final workshop in 2024, it underscored that while hydrogen faces cost and infrastructure challenges, hydrogen holds potential for large vehicles with high payload demands. Refuse trucks present a good example of early penetration of hydrogen use cases, as their operation are likely following regular schedule within confined area which help to ensure steady utilization of HRS infrastructure. Another advantage of this demonstration is to promote hydrogen as an alternative clean vehicle as these trucks have good exposure to public while hovering around the city.

Project website: <https://h2revive.eu/revive-proudly-presents-project-video/>

6.4.3. H2Share

H2Share stands for 'Hydrogen Solutions for Heavy-duty transport Aimed at Reduction of Emissions' in North-West Europe led by WaterstofNet. This project not only demonstrates fuel-cell trucks but also features a low energy mobile refuelling station. The refuelling station is designed as a mobile, built using ADR BDF swap bodies, one configures as a tank container and the other as refueller container as seen in Figure 21. It has a discharging capacity of approximately 120 kg/day. The design promotes flexibility and portability as both containers can be transported using trailers capable of handling swap bodies. Because the tank and refueller are separate units, the tank can be transported independently to replenish hydrogen, allowing the mobile refueller to continue operating with stored hydrogen in the meantime. Key insights their demonstration highlight the importance of early engagement with local authorities who may not be familiar with hydrogen technologies. Initial discussion typically concerns safety and the intended use of the system. *Reference: Deliverable report* (H2Share, 2019)



Figure 23: Mobile HRS demonstration of H2Share

6.4.4. H2Haul

H2Haul is an EU-funded demonstration project focused on deploying hydrogen fuel cell trucks for zero-emission transport in Europe. Supported by the Clean Hydrogen Partnership (formerly FCH JU), the project involves the operation of 16 fuel cell heavy-duty trucks across Belgium, France, Germany, and Switzerland. Leading truck manufacturers such as IVECO and VDL supply the vehicles, while hydrogen refuelling stations are constructed along logistics corridor such as Fos-sur-Mer (France) and Ollignies (Belgium). Key partners in H2Haul include Air Liquide, H2Energy, Colruyt Group, and other logistics

operators, working together to validate the performance and viability of hydrogen trucks in real-world freight operations. (Project website: <https://www.h2haul.eu/about/>)

As of 2023, a high-pressure hydrogen refuelling station for trucks has been inaugurated in Fos-sur-Mer, Marseille, developed by Air Liquide. This station is also part of the HyAMMED (“Hydrogène à Aix-Marseille pour une Mobilité Ecologique et Durable”) initiative, supported by French government funding and part to the H2Haul project co-financed by the Clean Hydrogen Partnership. In parallel, a second high-capacity station (700 bar, 2 tons/day) is planned for installation in Salon-de-Provence, intended to support a fleet of 50 hydrogen IVECO trucks from 2025 as part of the R’HySE project demonstration. (HE Comms, 2023).

(Project website: <https://vigny.france-hydrogene.org/cartographie-des-projets-et-stations/>)

6.4.5. H2Accelerate

H2Accelerate is a collaborative European initiative focused on accelerating the deployment of hydrogen-powered heavy-duty vehicles and the supporting refuelling infrastructure. Funded by the Clean Hydrogen Partnership and the Connecting Europe Facility (CEF), the project demonstrates over 150 hydrogen fuel cell trucks across several countries, including the Netherlands, Germany, Belgium, and France by 2029. Leading manufacturers such as Daimler Truck, Volvo Group, and Iveco supply the vehicles. HRS are established in strategic transport corridors, notably in key logistics hubs within the participating countries. Main partners include Shell, TotalEnergies, Linde, and Everfuel who work together to scale up both vehicles and infrastructure. The primary objectives are to validate the operational performance of hydrogen trucks, foster market readiness, and lay the groundwork for a pan-European, zero-emission freight network.

(Project website: <https://h2accelerate.eu/about/>)

6.4.6. ZEFES, ESCALATE and EMPOWER

Along ZEFES, two other sister projects (ESCALATE and EMPOWER) are advancing the development of Fuel Cell Electric Vehicles (FCEVs) for long-haul applications.

ESCALATE focuses on demonstrating high-efficiency zero-emission heavy-duty vehicle powertrains, targeting up to 10% increase in efficiency and a driving range of 800 km without refuelling. The project promotes a concept of standardized, cost effective, modular, and scalable multi-powertrain components. The early pilot truck features a hydrogen-battery hybrid configuration, combination a hydrogen fuel cell system with advanced battery technology. The vehicle is built on a SISU platform tailored for heavy-duty conditions. The truck-trailer combination integrates a Ballard fuel cell system, 59kg hydrogen storage capacity, battery system which support rapid refuelling (up to 1000 kW), and includes regenerative braking to enhance energy efficiency.

Testing has revealed key design consideration for compatibility with HRS, including the need for low pressure drops in the truck refuelling line even at high flow rates (ESCALATE, 2024). In addition, its emphasis the importance of communication protocols during high flow fuelling to optimize performance and safety.

(Project website: <https://www.escalate-eu.com/hydrogen-fuel-cell-pilot/>)

EMPOWER (Eco-operated, Modular, highly efficient, and flexible multi-POWERtrain for long-haul heavy-duty vehicles) is funded under Horizon Europe framework through the 2Zero Partnership. The project aims to develop two flexible, modular, and scalable HD ZEV with a target market entry by 2029: One fully electric-powered truck, one hybrid fuel-cell battery-powered truck for long-haul operations. Although vehicle deployment is still underway, the integration of fuel cell system has already led to the development of a highly efficient and adaptable fuel cell system to meet the stringent performance and operational targets set for the next generation HD ZEVs.

(Project website: <https://www.projectempower.eu/cluster/>)

6.4.7. Hyundai Hydrogen Mobility

Hyundai has been developing heavy duty fuel cell trucks with up to 42 tons, which are available on Switzerland and Germany. In 2024, a total of 48 XCIENT Fuel Cell trucks are in operation in Switzerland. The XCIENT Fuel Cell is powered by two 90-kW fuel cell systems (total 180 kW power) and a 350-kW e-motor, giving a maximum range of over 400 km.

7. Contribution

7.1. Contribution to ZEFES

This work directly supports ZEFES Objective 2, which focuses on mapping European corridors suitable for the successful rollout HD-ZEVs across Europe. Logistic operations require well-distributed HRS locations for HD-FCEVs. The infrastructure mapping via online platforms (map) and exploration of planned stations helps to ensure the availability of adequate infrastructure for ZEFES demonstration (VC15).

7.2. Contribution to exploitable results

The report analyses publicly accessible information of HRS, to map suitable HRS for the 6 ZEFES UC demonstration of HD-FCEV and assess whether the needed infrastructure is available to conduct the demonstrations. Moreover, the exploration on existing HRS location platforms (maps) has revealed missing data points, such as HDV compatibility, HDV accessibility and other dynamic information which are essential to ensure efficient long-haul logistics mission using HD-FCEV. These findings can be used to define the routes of the ZEFES use cases.

8. Conclusion and Recommendation

8.1. Conclusion

The mapping and analysis of HRS infrastructure indicate that the current European network still faces limitations in supporting long-haul FCEV logistics. While some progress has been made in selected countries, the distribution of HRS suitable for HD-FCEV remains uneven. Many HRS are still under construction, are not compatible with 700 bar systems required for HD-FCEVs, or even not accessible by truck-trailer combinations. These limitations impact the feasibility of the ZEFES use-case deployment, requiring mitigation actions, like route adjustments. The final ZEFES Use Cases will be described in public Deliverable 7.2 Overview performed use cases, planned to finalise in month 42

The work identified several established public-accessible platforms that display the location and status of HRS. While these tools offer valuable visibility into refuelling points, they fall short in supporting real-time logistics planning. In practice, truck operators still need to verify station accessibility and technical specifications, particularly regarding compatibility with HDVs. This limits the operational reliability of FCEV-based logistics and highlights the need for more integrated and data-rich infrastructure platforms.

8.2. Recommendations

The recommendations are grouped into actions during the project and beyond its scope.

During the ZEFES demonstration

Given the limited adequacy of HRS infrastructure, with few or no viable alternatives along certain routes, tight coordination among project partners is essential. This involves early confirmation with station operators to ensure that each site can meet the specific needs of the ZEFES demonstration, including accessibility, fuel quantity availability, and technical compatibility with HD-FCEVs.

Integrating HRS locators with e-routing platforms can improve the reliability of HD-FCEVs for long-haul missions by aligning route planning with estimated hydrogen consumption, refuelling locations, and schedules. For example, incorporating HD-FCEV-compatible HRS data to truck routing simulators like PTV Logistics's tools enables trip feasibility assessment based on current infrastructure, while also providing estimates on hydrogen refuelling mass needs on every truck stop.

Proposal beyond the project demonstration

- i. Leverage infrastructure gap findings to develop replicable corridor deployment models of long-haul FCEV logistics mission.
- ii. Enrich information exchange between HRS operators and locator platforms to enhance real-time visibility and reliability for logistics planning.
- iii. Further research in vehicle design and charging hub layout, to improve the capabilities of both and achieve efficient and interoperable assets. For example, the ability to monitor the hydrogen fuel quality at station and vehicle level could improve the performance and lifetime of both.
- iv. Strengthening collaboration across the hydrogen value chain, fostering coordinated investment and shared risk mitigation. This aligns with efforts to support business model viability through targeted funding schemes at EU, national, and regional levels, helping reduce capital expenditure (CAPEX) for station operators and total cost of ownership (TCO) for fleet operators.

9. Risks and interconnections

9.1. Risks/problems encountered

Table 8 Risk assessment and counter measures

Risk No.	What is the risk	Probability of risk occurrence ¹	Effect of risk ¹	Solutions to overcome the risk
WP7, WP3	Availability of hydrogen refuelling station	2	Cancellation of HD-FCEVs demonstration	WP3 to map electric charging station along the demo route for contingency plan in case of fuel runout.
WP7, WP3	Lack of visibility over HRS compatible with 700 bars for HDV	3	Disruption during vehicle demonstration	WP3 taskforce to reach out to station operator to validate compatibility of refuelling and communication protocol, as well ensure as adequate fuel supply
WP7, WP1	Regulatory issues prevent doing the demonstrations	2	Cancellation of HD-FCEV demonstration on certain country	Combine demonstration of UCs, reroute, and adapt use case to a country where registration is possible
WP3	Potential dependency on D3.6 (Infrastructure Requirements Definition) outcomes	2	1	Regular update and coordination with D3.6 team; Set up internal review by exchanging the documents to proof-read

¹⁾ Probability risk will occur: 1 = high, 2 = medium, 3 = Low

9.2. Interconnections with other deliverables

The deliverable 3.5 showcases the readiness of hydrogen refuelling infrastructure along TEN-T corridors, which correspond to the HD-FCEVs demonstrations. The mapping exercise results are used for the demonstration roll out on the later WP7. Then, the outcomes from the demonstration, combined with infrastructure readiness data from both MCS (D3.6) and HRS (D3.5), will inform the use-case evaluation in Work Package 8 (WP8). This assessment will help determine which types of long-haul heavy-duty transport use-cases, and under what conditions, FCEV or BEV technologies offer practical pathways toward zero-emission transport, in line with Objective 3.1 of WP8.

References

- A World Of Energy. (2022, 4 3). *Hydrogen Refuelling Station*. Retrieved from AWOE.net: <https://www.awoe.net/Hydrogen-Refuelling.html>
- Certifhy. (2024). *Certifhy: Leading hydrogen certification*. Retrieved from <https://www.certifhy.eu/our-mission-and-vision/>
- Clean Hydrogen Partnership. (2025). *Clean Hydrogen Partnership*. Retrieved from https://www.clean-hydrogen.europa.eu/about-us/mission-objectives_en
- Daimler Truck AG. (2023, 9 6). *Mercedes-Benz GenH2 Truck cracks 1,000 kilometer mark with one fill of liquid hydrogen*. Retrieved 11 17, 2025, from Daimler Truck: <https://www.daimlertruck.com/en/newsroom/pressrelease/daimler-truck-hydrogenrecordrun-mercedes-benz-genh2-truck-cracks-1000-kilometer-mark-with-one-fill-of-liquid-hydrogen-52369346>
- ESCALATE. (2024). *D4.2 Refuelling Solutions and Protocols*. Project deliverable. Retrieved from <https://www.escalate-eu.com/wp-content/uploads/2025/04/D4.2-Refuelling-solutions-and-protocols.pdf>
- European Alternative Fuels Observatory. (2025). *Interactive map: Recharging and refuelling*. European Commission. Retrieved 11 11, 2025, from <https://alternative-fuels-observatory.ec.europa.eu/interactive-map>
- European Hydrogen Observatory. (2025, 6 20). *European Hydrogen Bank*. Retrieved from Clean Hydrogen Europa: <https://observatory.clean-hydrogen.europa.eu/eu-policy/european-hydrogen-bank>
- European Hydrogen Observatory. (2025, 10 15). *Geomap*. Dashboard. Retrieved 11 11, 2025, from observatory clean hydrogen: <https://observatory.clean-hydrogen.europa.eu/tools-reports/geomap>
- European Union. (2023). Regulation (EU) 2023/1804 of the European Parliament and of the Council of 13 September 2023 on the deployment of alternative fuels infrastructure, and repealing Directive 2014/94/EU. *Official Journal of the European Union*. Retrieved from <https://eur-lex.europa.eu/legal-content/EN/TXT/?uri=CELEX%3A32023R1804>
- European Union. (2025, 4 2). *COMMISSION IMPLEMENTING REGULATION (EU) 2025/655*. Retrieved from EUR-Lex: https://eur-lex.europa.eu/eli/reg_impl/2025/655/oj/eng
- Fuel Wells Works. (2025, 4 22). *OMV to Close All Public Hydrogen Fuel Stations in Austria by September*. Retrieved from Hydrogen Mobility: <https://fuelcellsworks.com/2025/04/22/fuel-cells/omv-to-close-all-public-hydrogen-fuel-stations-in-austria-by-september>
- H2Share. (2019, 3). *Report with design specifications of the mobile hydrogen refuelling station*. Retrieved from Interreg North-West Europe: <https://vb.nweurope.eu/media/5797/del-i2-1-1-report-with-design-specifications-mobile-refueler-final.pdf>
- HE Comms. (2023, 6 27). *Air Liquide and Iveco Group reaffirm their commitment to hydrogen at the inauguration of the first high-pressure hydrogen station for long-haul trucks in Europe*. Retrieved from H2HAUL: <https://www.h2haul.eu/air-liquide-and-iveco-group-reaffirm-their-commitment-to-hydrogen-at-the-inauguration-of-the-first-high-pressure-hydrogen-station-for-long-haul-trucks-in-europe/>

- HIL. (2025). *Five More Hydrogen Refuelling Stations to be Built in Poland*. Retrieved from Hydrogen Industry Leader: <https://hydrogenindustryleaders.com/five-more-hydrogen-refuelling-stations-to-be-built-in-poland/>
- Hydri. (2025, 3 5). *Hydri Opens Its Third Green Hydrogen Station in Nykvarn*. Retrieved 11 18, 2025, from <https://hydri.energy/en/news/hydri-inaugurates-its-third-green-water-gas-station-in-nykvarn/>
- Hydrospider. (2025). *HRS H2 Versorgung-Status*. Retrieved 11 11, 2025, from <https://hydrospider.alpiq.services/hrs-status>
- Hynion. (2025, 5 19). *Hynion AS subsidiary Hynion Sverige AB files for bankruptcy*. Retrieved from <https://www.hynion.com/news/hynion-as-subsiary-hynion-sverige-ab-files-for-bankruptcy>
- Hytruck. (2024). *A catalog of technical standards and norms for hydrogen refueling stations dedicated for heavy duty transportation in the BSR*. Project deliverable. Retrieved from <https://sumin.lrv.lt/public/canonical/1736518551/12698/A%20catalog%20of%20technical%20standards%20and%20norms%20for%20hydrogen%20refueling%20stations%20dedicated%20for%20heavy%20duty%20transportation%20in%20the%20BSR.pdf>
- Hyundai Hydrogen Mobility. (2025, 7 1). *Premiere: Hyundai launches the first hydrogen-powered hook-lift and waste collection trucks*. Retrieved from [hyundaihm.com: https://hyundaihm.com/en/premiere-hyundai-launches-the-first-hydrogen-powered-hook-lift-and-waste-collection-trucks/](https://hyundaihm.com/en/premiere-hyundai-launches-the-first-hydrogen-powered-hook-lift-and-waste-collection-trucks/)
- JIVE 2. (2025, 10 22). *Project factsheet*. Retrieved from Clean Hydrogen Partnership: https://www.clean-hydrogen.europa.eu/projects-dashboard/projects-repository/jive-2_en
- Klimafreundliche Nutzfahrzeuge. (2025). *Fahrzeugdatenbank*. Retrieved from Gesamtkonzept Klimafreundliche Nutzfahrzeuge: https://www.klimafreundliche-nutzfahrzeuge.de/fahrzeugdatenbank/?_sft_antriebsart=h2-brennstoffzelle,h2-verbrenner
- L'observatoire de l'hydrogène. (2025). *Cartographie des projets et stations*. Retrieved 11 11, 2025, from <https://vigny.france-hydrogene.org/cartographie-des-projets-et-stations/>
- Metacon AB. (2025, 10 14). Retrieved from Metacon acquires Hynion Sweden's bankruptcy estate: <https://news.cision.com/metacon-ab/r/metacon-acquires-hynion-sweden-s-bankruptcy-estate,c4250167>
- Neso. (2025). *Hydrogen refueling station*. Retrieved 11 11, 2025, from <https://stacjeneso.pl/en/>
- NewBusFuel Project. (2017, 3 15). *New Bus ReFuelling for European Hydrogen Bus Depots*. Retrieved from https://www.fuelcellbuses.eu/sites/default/files/documents/NewBusFuel_D4.3_Guidance-document-for-large-scale-hydrogen-refuelling_final.pdf
- NOW GmbH. (2025). *Research & Development in NIP*. Retrieved from <https://www.now-gmbh.de/en/funding/funding-programmes/hydrogen-and-fuel-cell/research-development-in-nip/?step1=components-and-systems&step2=refueling-and-infrastructure-components>
- PRHYDE. (2024, 7 3). *Protocol for heavy duty hydrogen refuelling Factsheet*. Retrieved from Clean Hydrogen Partnership: https://www.clean-hydrogen.europa.eu/projects-dashboard/projects-repository/prhyde_en
- REVIVE. (2025, 3 6). *REVIVE Project Concludes its Successful Demonstration of Hydrogen Fuel Cell Refuse Trucks Across Europe*. Retrieved from <https://www.waterstofnet.eu/en/news/revive->

project-concludes-its-successful-demonstration-of-hydrogen-fuel-cell-refuse-trucks-across-europe

TENtec. (2025). *TENtec maps*. Retrieved 11 11, 2025, from European Comission: <https://webgate.ec.europa.eu/tentec-maps/web/public/screen/home>

Valenciaport. (2023, 4 27). *Valenciaport becomes the first port in the world to operate hydrogen-powered 4x4 trucks at its terminals*. Retrieved 11 18, 2025, from <https://www.valenciaport.com/en/valenciaport-becomes-the-first-port-in-the-world-to-operate-hydrogen-powered-4x4-trucks-at-its-terminals/>

Acknowledgement

The author(s) would like to thank the partners in the project for their valuable comments on previous drafts and for performing the review.

Project partners:

#	Partner short name	Partner Full Name
1	VUB	VRIJE UNIVERSITEIT BRUSSEL
2	FRD	FORD OTOMOTIV SANAYI ANONIM SIRKETI
4	KAE	KASSBOHRER FAHRZEUGWERKE GMBH
5	REN	RENAULT TRUCKS SAS
6	SCA	SCANIA CV AB
7	VET	VAN ECK TRAILERS BV
8	VOL	VOLVO TECHNOLOGY AB
8.1	CPA	CPAC SYSTEMS AB
9	ABB	ABB E-MOBILITY BV
9.1	ABP	ABB E-MOBILITY SPOLKA Z OGRANICZONAODPOWIEDZIALNOSCIA
9.2	ABG	ABB E-MOBILITY GMBH
10	AVL	AVL LIST GMBH
11	CM	SOCIEDAD ESPANOLA DE CARBUROS METALICOS SA
11.1	APG	AIR PRODUCTS GMBH
12	HEPL	HITACHI ENERGY POLAND SPOLKA Z OGRANICZONA ODPOWIEDZIALNOSCIA
13	MIC	MANUFACTURE FRANCAISE DES PNEUMATIQUES MICHELIN
14	POW	OPmobility
15	RIC-CZ	RICARDO PRAGUE S.R.O.
15.1	RIC-DE	RICARDO GMBH
16	UNR	UNIRESEARCH BV
17	ZF	ZF CV SYSTEMS HANNOVER GMBH
18	ALI	ALLIANCE FOR LOGISTICS INNOVATION THROUGH COLLABORATION IN EUROPE
19	DPD	DPD (NEDERLAND) B.V.
20	COL	ETABLISSEMENTEN FRANZ COLRUYT NV
21	GRU	GRUBER LOGISTICS S.P.A.
22	GBW	GEBRUEDER WEISS GESELLSCHAFT M.B.H.
23	PG	PROCTER & GAMBLE SERVICES COMPANY NV
23.1	PGP	PROCTER AND GAMBLE POLSKA SPOLKA Z OGRANICZONA ODPOWIEDZIALNOSCIA
23.2	PGA	PROCTER & GAMBLE AMIENS
23.3	PGG	PROCTER & GAMBLE SERVICE GMBH
24	PRI	PRIMAFRIO CORPORACION, S.A.
25	PTV	PTV PLANUNG TRANSPORT VERKEHR GmbH

26	Fraunhofer	FRAUNHOFER GESELLSCHAFT ZUR FORDERUNG DER ANGEWANDTEN FORSCHUNG EV
27	HAN	STICHTING HOGESCHOOL VAN ARNHEM ENNIJMEGEN HAN
28	IDI	IDIADA AUTOMOTIVE TECHNOLOGY SA
29	TNO	NEDERLANDSE ORGANISATIE VOOR TOEGEPAST NATUURWETENSCHAPPELIJK ONDERZOEK TNO
30	UIC	UNION INTERNATIONALE DES CHEMINS DE FER
31	CFL	CFL MULTIMODAL S.A.
32	GSS	Grupo Logistico Sese
33	HIT	Hitachi ABB Power Grids Ltd.
34	IRU	UNION INTERNATIONALE DES TRANSPORTS ROUTIERS (IRU)
35	RIC-UK	RICARDO CONSULTING ENGINEERS LIMITED

Disclaimer/ Acknowledgment



Funded by the European Union

Copyright ©, all rights reserved. This document or any part thereof may not be made public or disclosed, copied or otherwise reproduced or used in any form or by any means, without prior permission in writing from the ZEFES Consortium. Neither the ZEFES Consortium nor any of its members, their officers, employees or agents shall be liable or responsible, in negligence or otherwise, for any loss, damage or expense whatever sustained by any person as a result of the use, in any manner or form, of any knowledge, information or data contained in this document, or due to any inaccuracy, omission or error therein contained.

All Intellectual Property Rights, know-how and information provided by and/or arising from this document, such as designs, documentation, as well as preparatory material in that regard, is and shall remain the exclusive property of the ZEFES Consortium and any of its members or its licensors. Nothing contained in this document shall give, or shall be construed as giving, any right, title, ownership, interest, license or any other right in or to any IP, know-how and information.

Funded by the European Union. Views and opinions expressed are however those of the author(s) only and do not necessarily reflect those of the European Union or the European Commission. Neither the European Union nor the granting authority can be held responsible for them.